

Past the Perimeter: Low-Cost Memory Interposer Attacks on Confidential Computing

Jo Van Bulck

🏠 DistriNet, KU Leuven, Belgium ✉️ jo.vanbulck@cs.kuleuven.be 🌐 vanbulck.net

TU Graz – May 7, 2026

Confidential Computing?

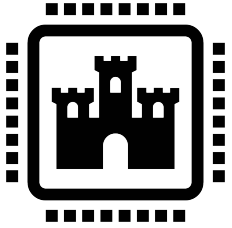

“Confidential Computing is the **protection of data in use** by performing computation in a **hardware-based, attested Trusted Execution Environment.**”



“Confidential computing enables **new public cloud scenarios** (e.g., migrating **extremely sensitive data** [...])”

Confidential Computing: Reducing Attack Surface

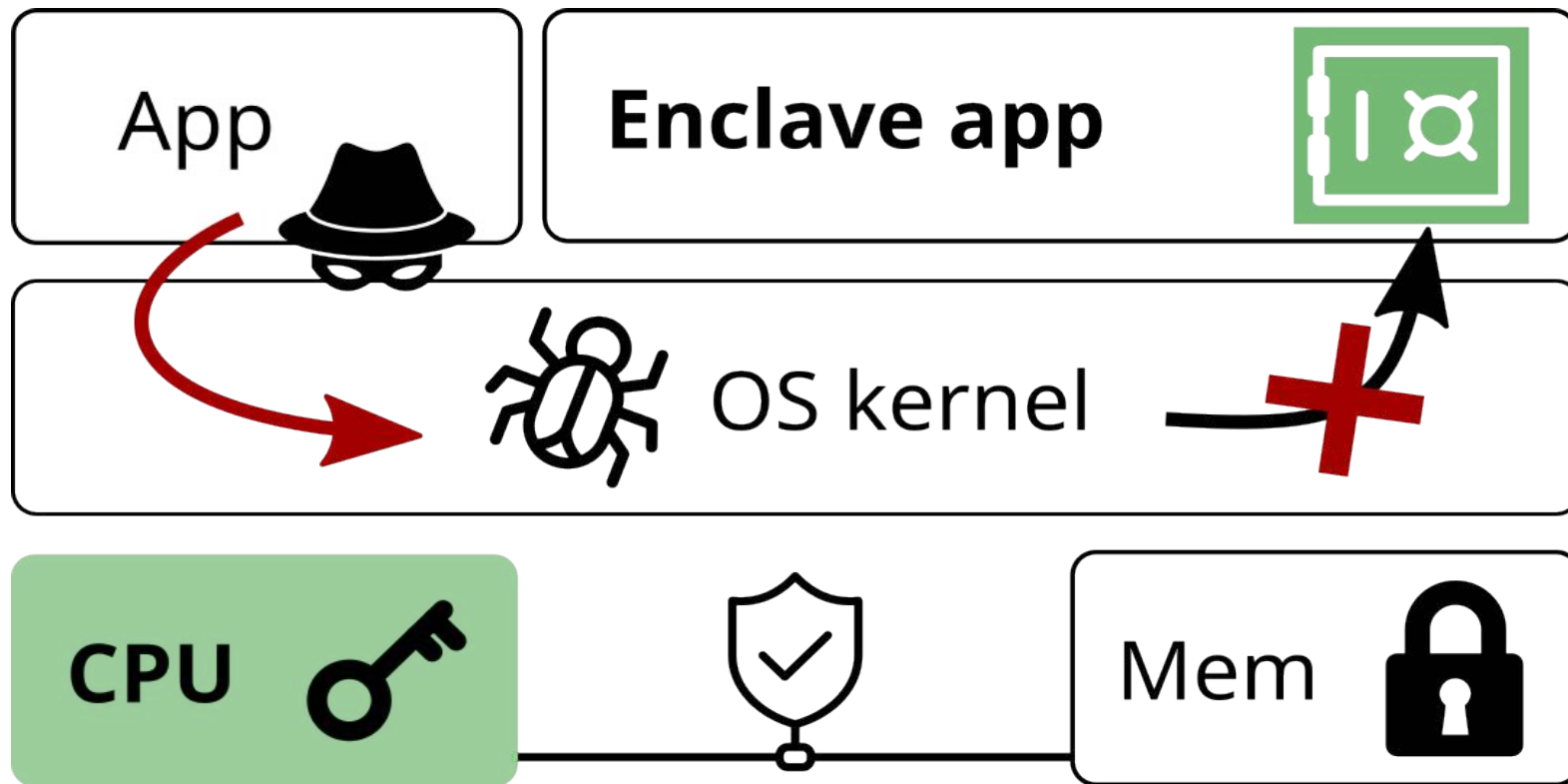

Trusted execution: Hardware-level **isolation and attestation**

The Rise of Trusted Execution Environments (TEEs)

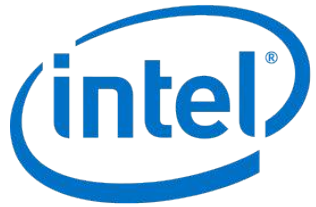

- 2004: ARM TrustZone
- 2015: **Intel Software Guard Extensions (SGX)**
- 2016: AMD Secure Encrypted Virtualization (SEV)
- 2018: IBM Protected Execution Facility (PEF)
- 2020: AMD SEV with Secure Nested Paging (SEV-SNP)
- 2022: Intel Trust Domain Extensions (TDX)
- 2023: ARM Confidential Compute Architecture (CCA)
- 2024: NVIDIA Confidential Computing



TEEs are here to stay...

The Rise of Confidential Cloud Computing

DARKREADING

Cloud Providers Throw Their Weight Behind Confidential Computing

New technologies designed into processors allow enterprises to leverage cloud advantages while meeting privacy regulations.

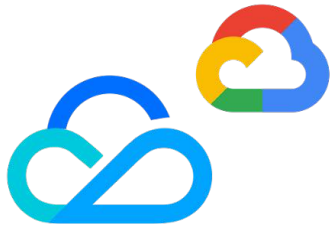

Tencent Cloud

Google Cloud



E Q U I N I X



IBM **Cloud**



Confidential Computing Today, Computing Tomorrow



*In the near future,
“confidential computing” will
just be “computing.”**

** Mark Russinovich, CTO
Microsoft Azure*





Confidential Computing: The Weakest Link?



Confidential Computing: Trust Boundary

- CPU package = trust boundary

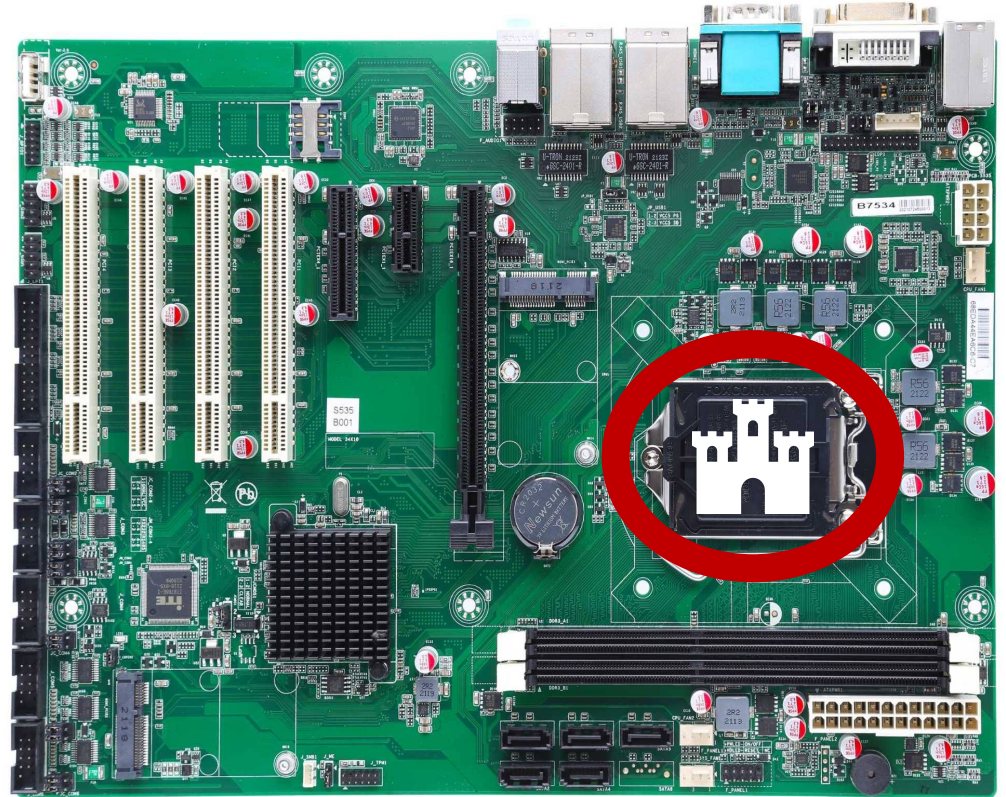

Confidential Computing: Trust Boundary

- CPU package = **trust boundary**
- Memory encryption to protect against physical access:
 1. Rogue cloud provider **employees**
 2. **Supply-chain** adversaries
 3. Local **law enforcement**

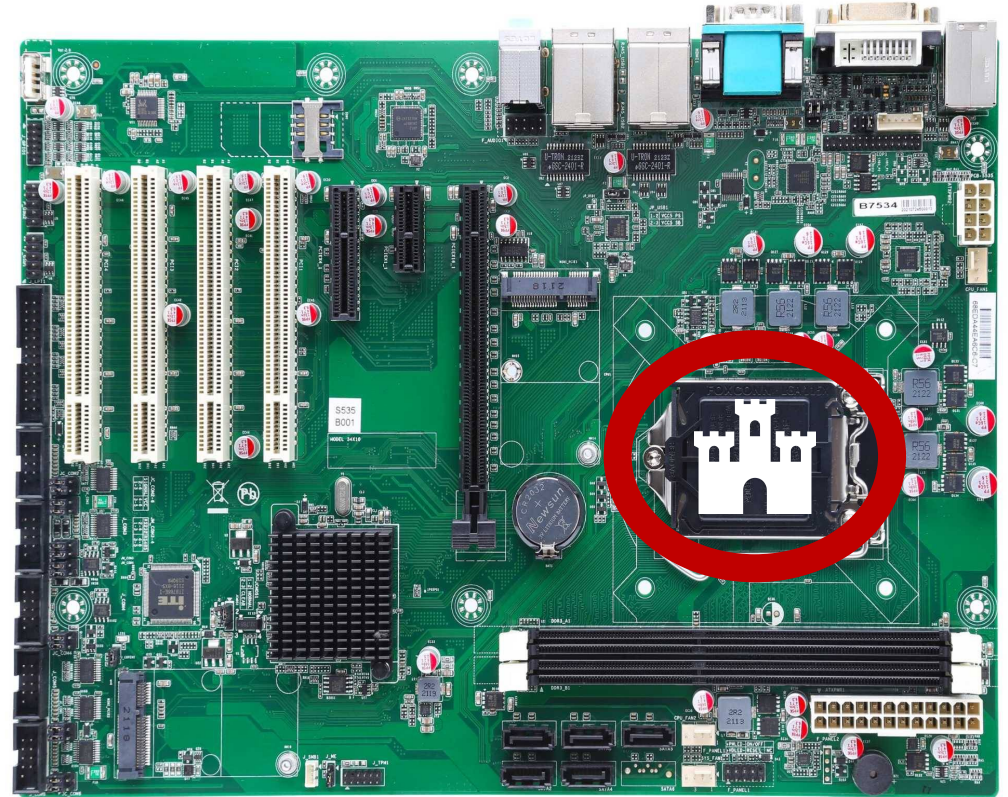

A Brief History of Commercial Memory Encryption

intel.

SGX

2015

Confidentiality



Integrity



Freshness



Scalable



A Brief History of Commercial Memory Encryption

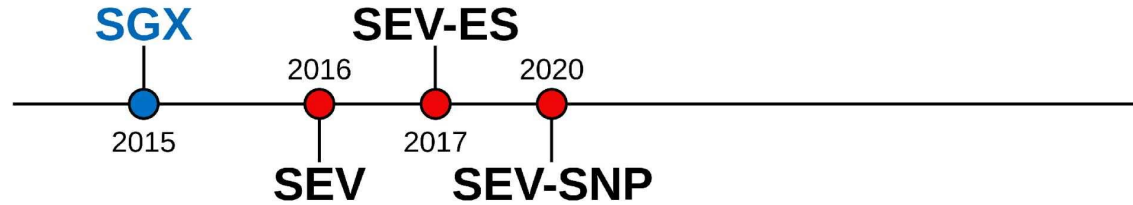

Confidentiality				
Integrity				
Freshness				
Scalable				



A Brief History of Commercial Memory Encryption



CLOUD

OPERATIONS & MANAGEMENT

NEWS

Why Google Cloud Turned to AMD to Solve for Runtime Encryption

AMD's latest server chips enabled better scalability, less lag, and more memory than Intel SGX, the cloud provider said.



Maria Korolov

July 21, 2020

🕒 5 Min Read

A Brief History of Commercial Memory Encryption

🔧 PUTTING ON A BRAVE FACE

Intel promises Full Memory Encryption in upcoming CPUs

Intel's security plans sound a lot like "we're going to catch up to AMD."

JIM SALTER - FEB 26, 2020 8:29 PM | 120

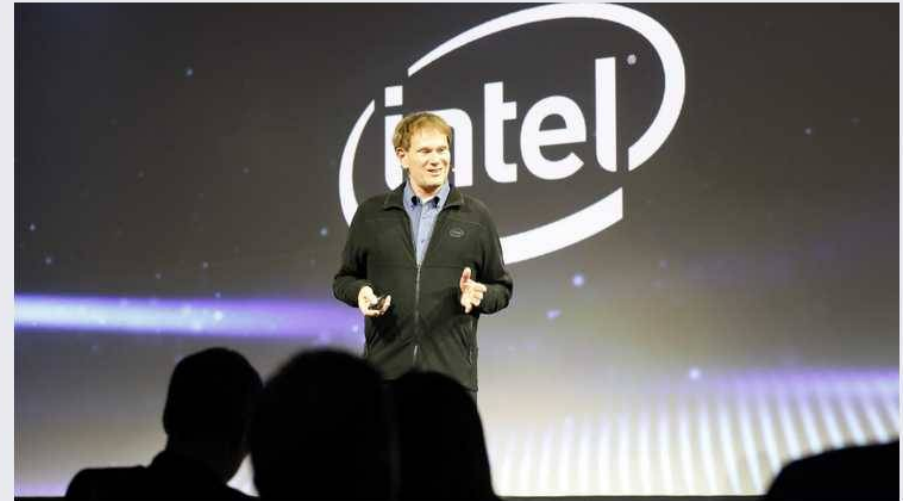

⇒ Intel Security Architecture and Technology Director John Sell provided an overview of Intel's mission to provide common security capabilities across all architectures. Credit: Intel Corporation

A Brief History of Commercial Memory Encryption

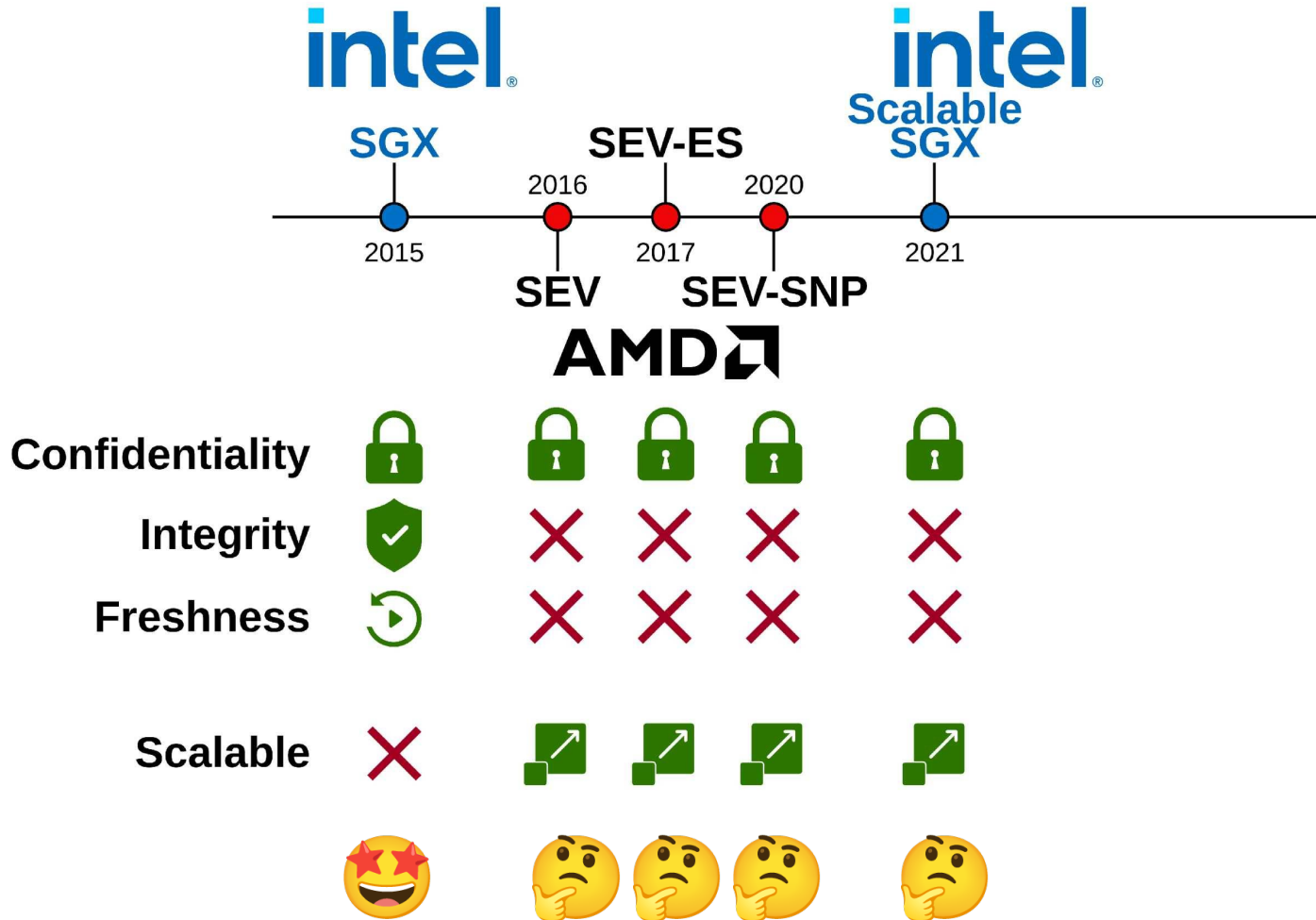

A Brief History of Commercial Memory Encryption

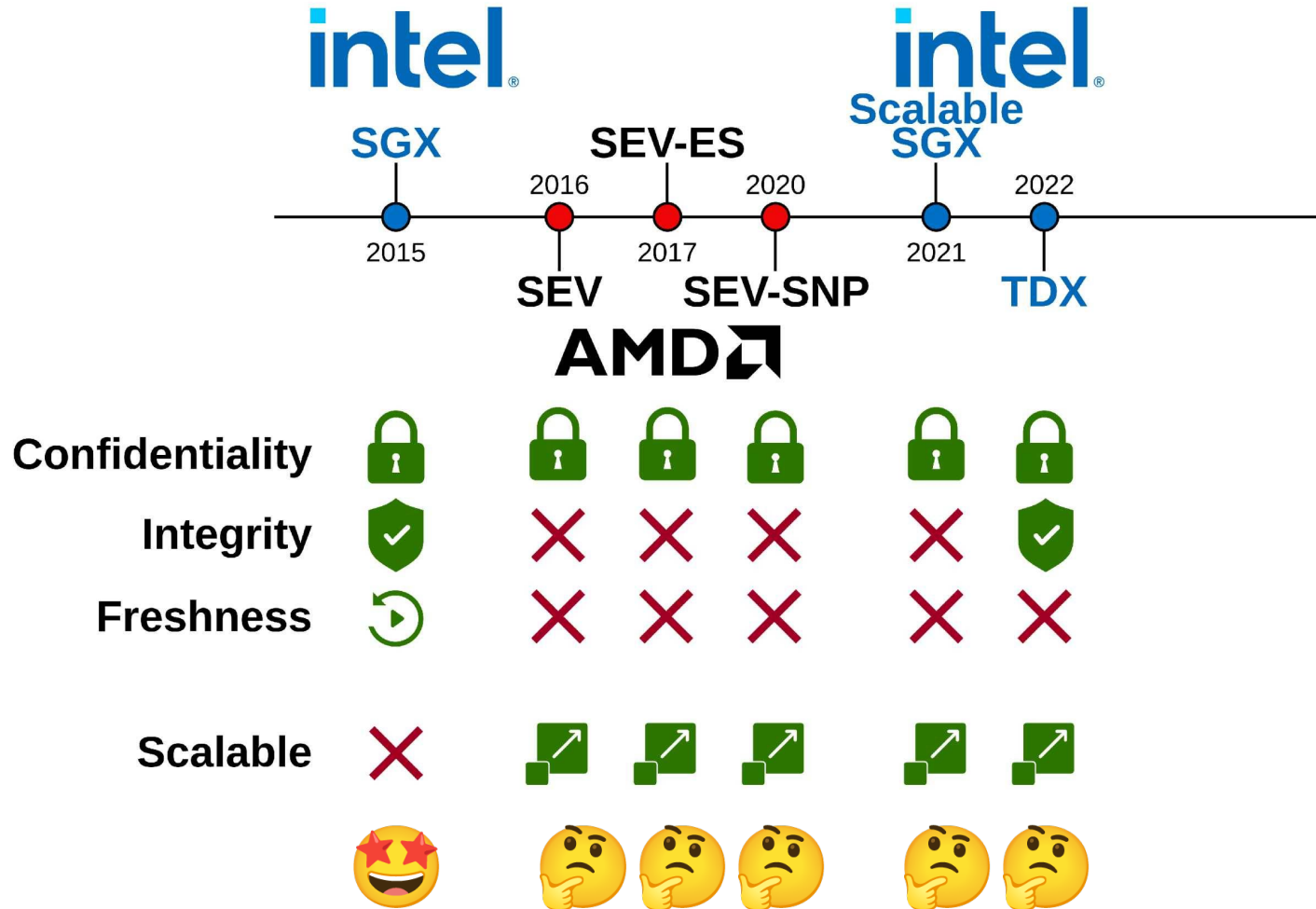

A Brief History of Commercial Memory Encryption

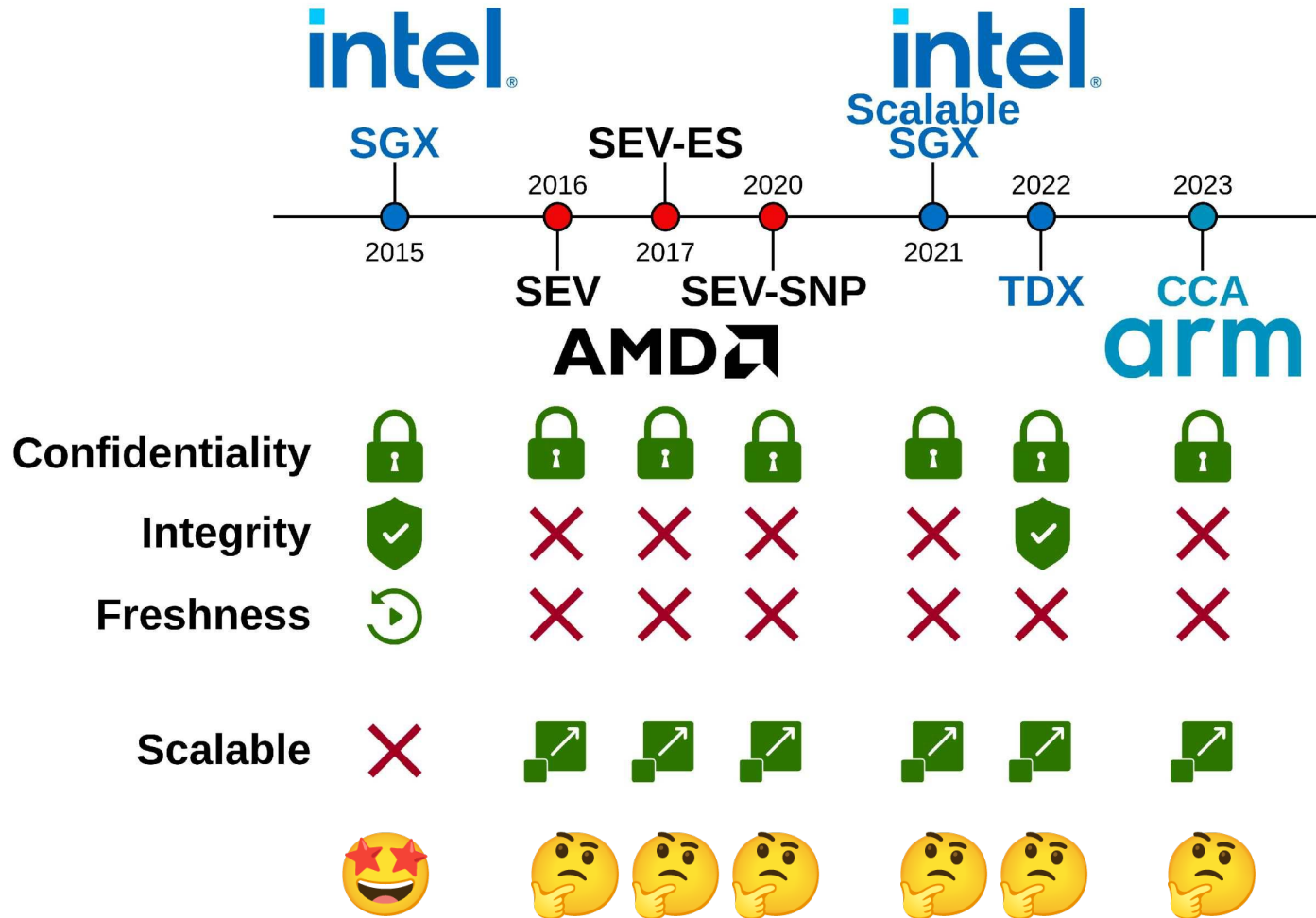

A Brief History of Commercial Memory Encryption

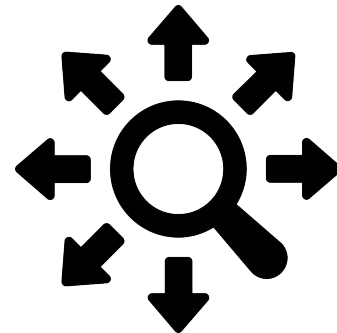
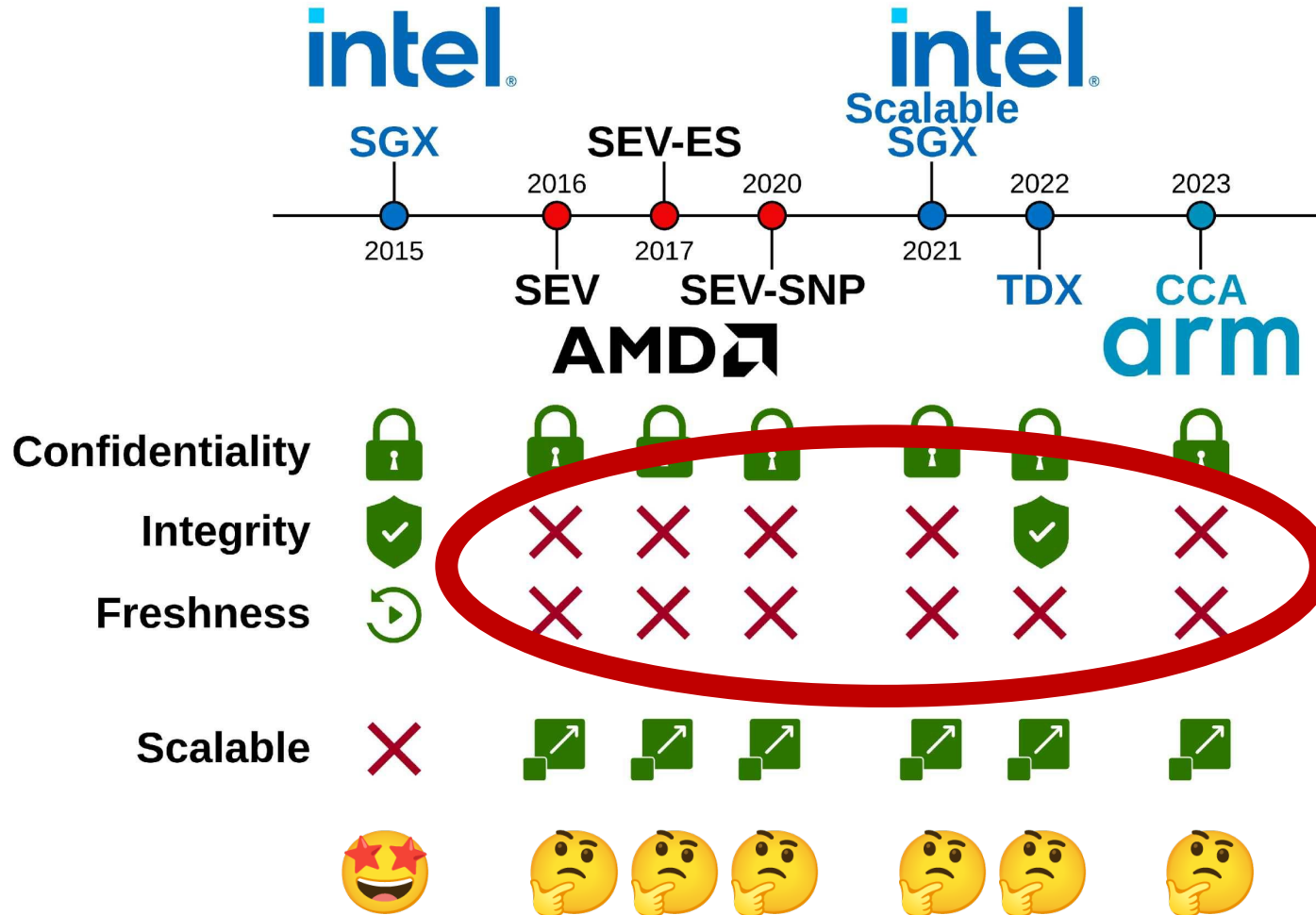



Idea #0: Commercial Interposers?

MemBuster: Address Side-Channel Analysis for “Classic” SGX

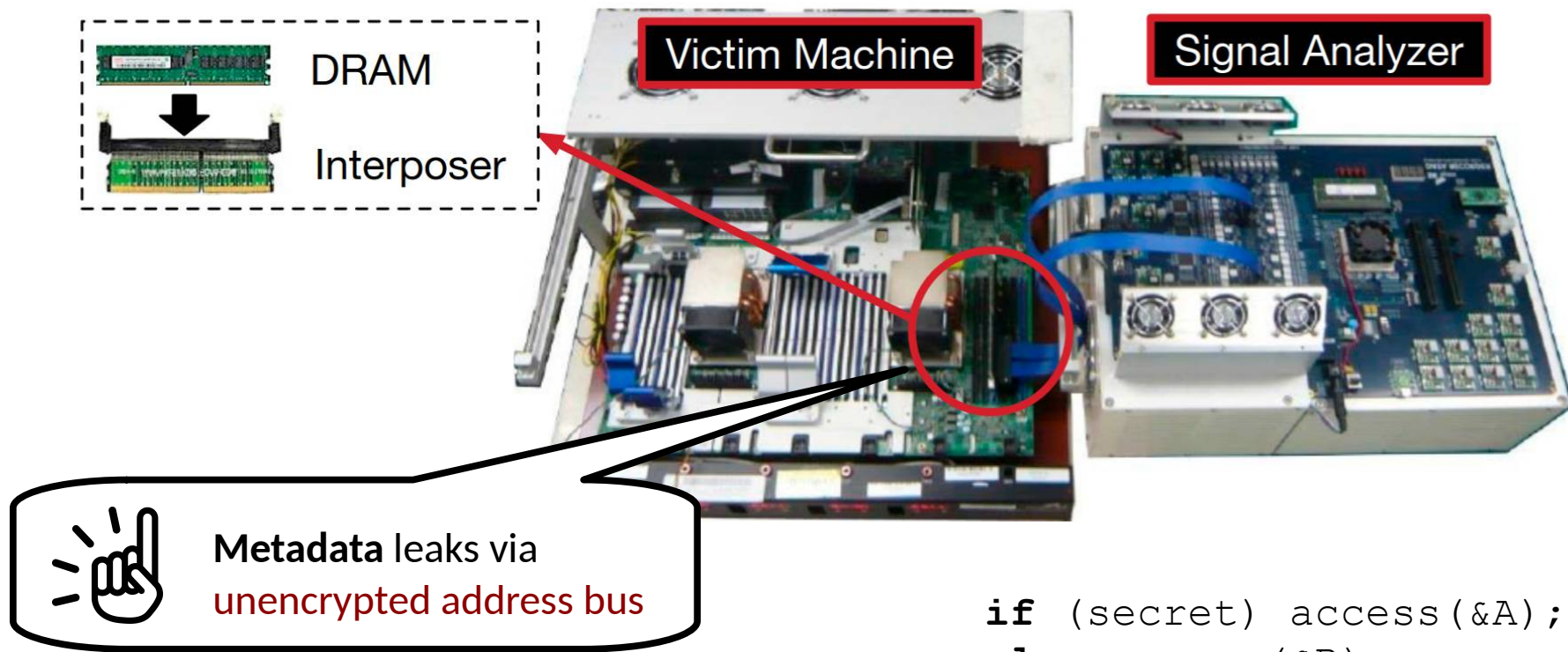

```
if (secret) access (&A);  
else access (&B);
```

MemBuster: Address Side-Channel Analysis for “Classic” SGX

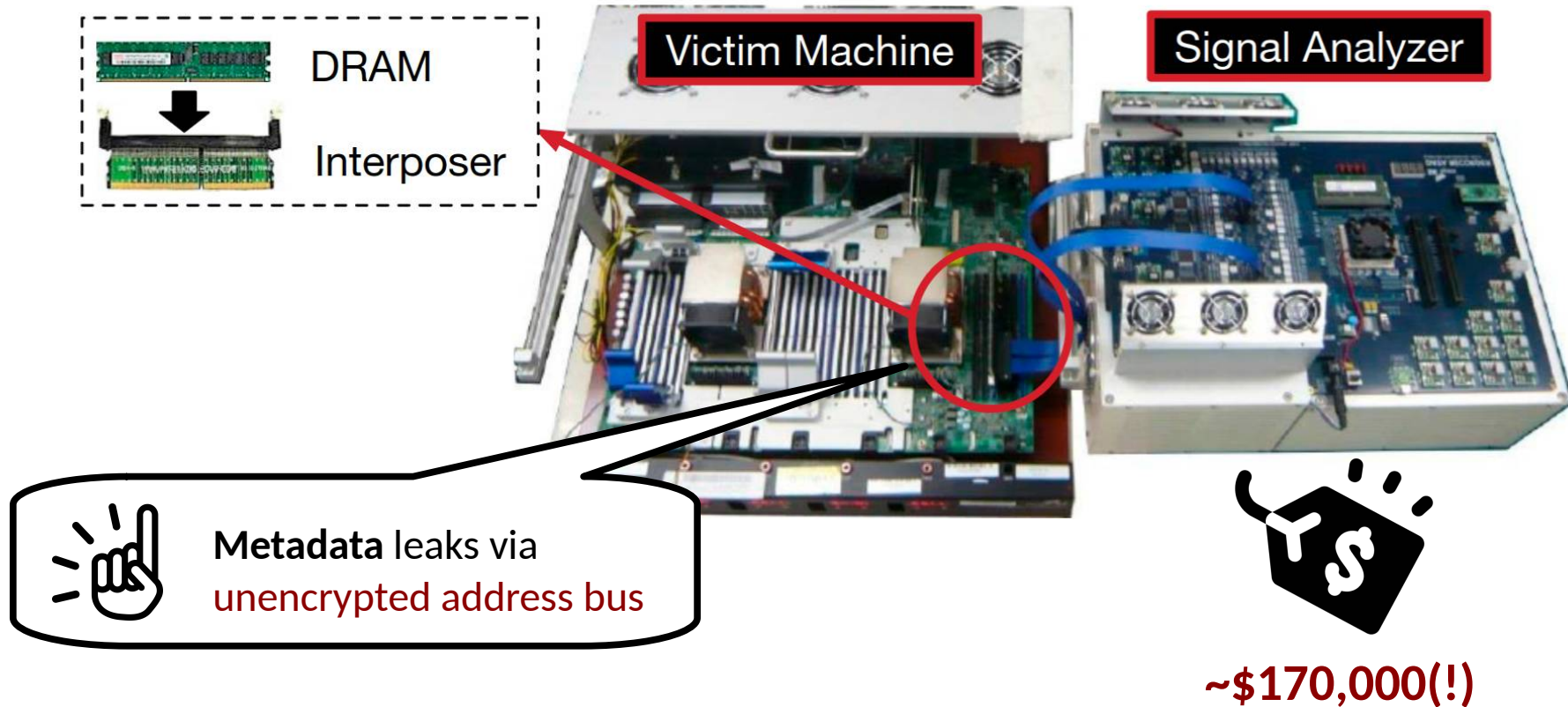

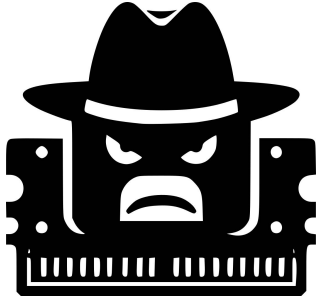

Idea #1: Malicious DRAM Initialization

Background: Memory Initialization

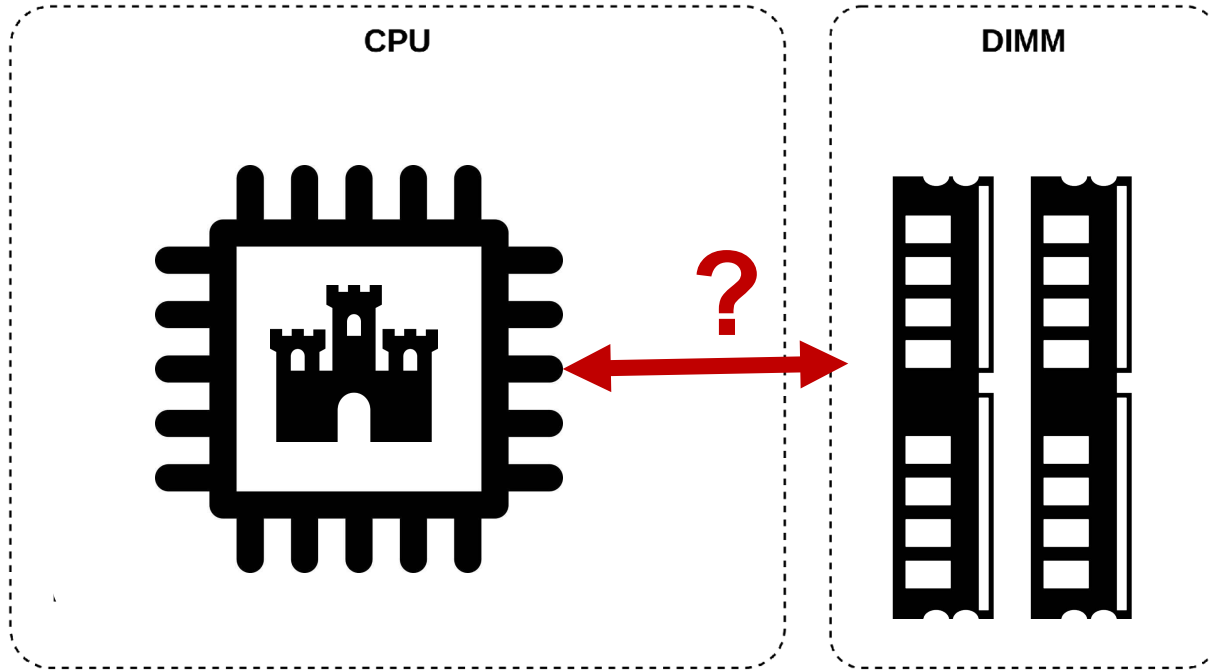

Background: Memory Initialization - Serial Presence Detect (SPD)

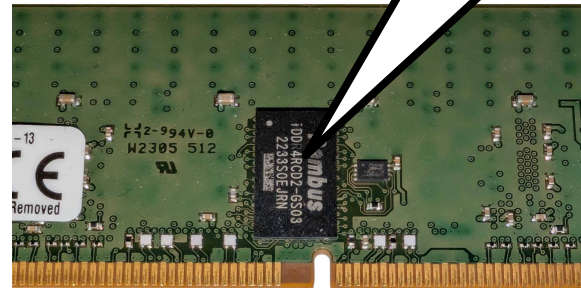
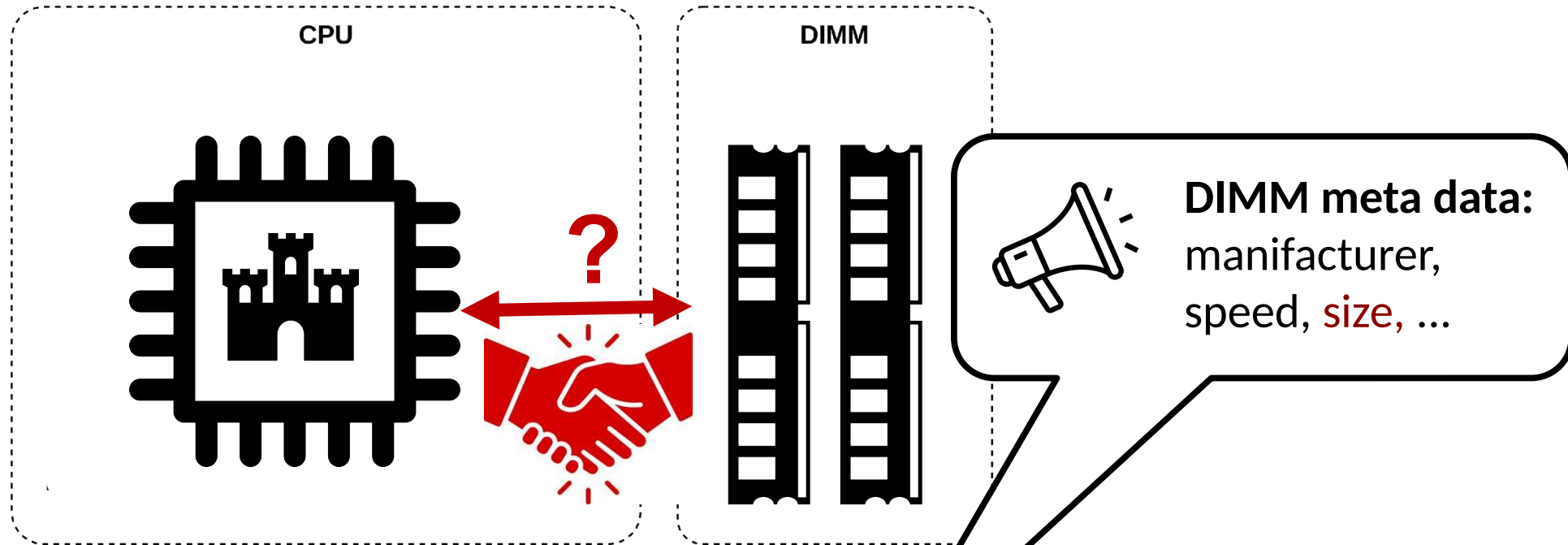

BadRAM: Overwriting the on-DIMM SPD Chip

- I²C pins exposed on DIMM
- Trivial to unlock and overwrite
- **Total cost: ~10\$**

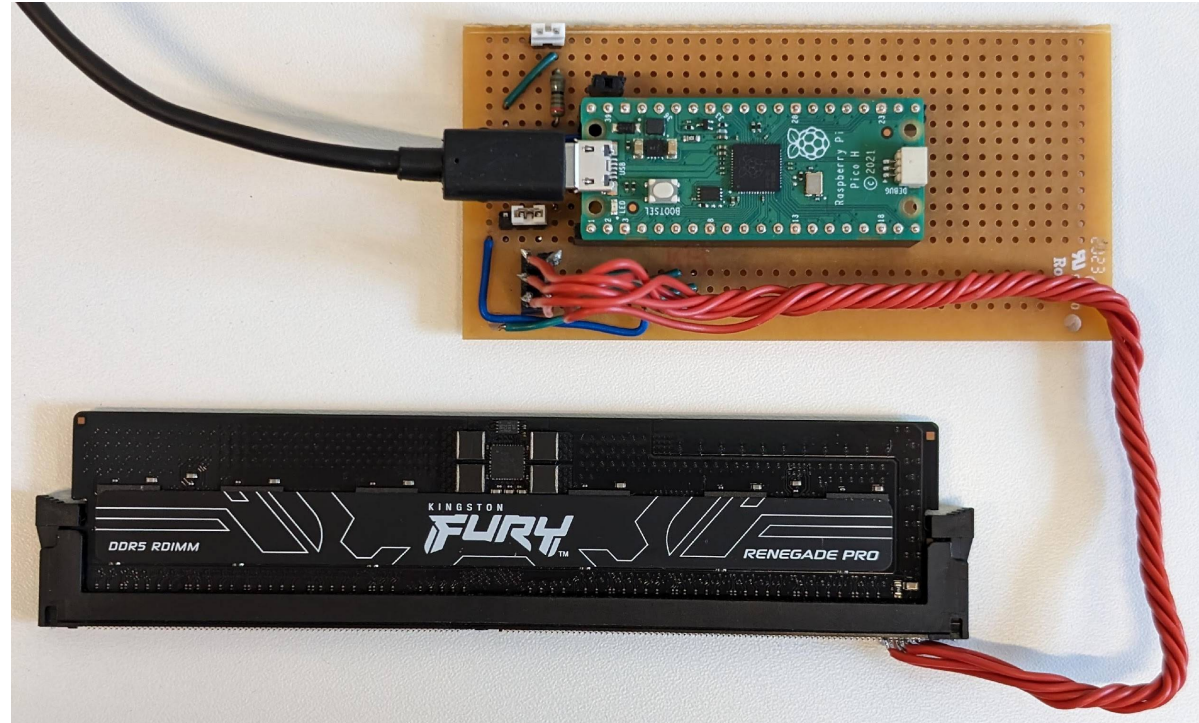

BadRAM: What if Your DRAM Lies to You?

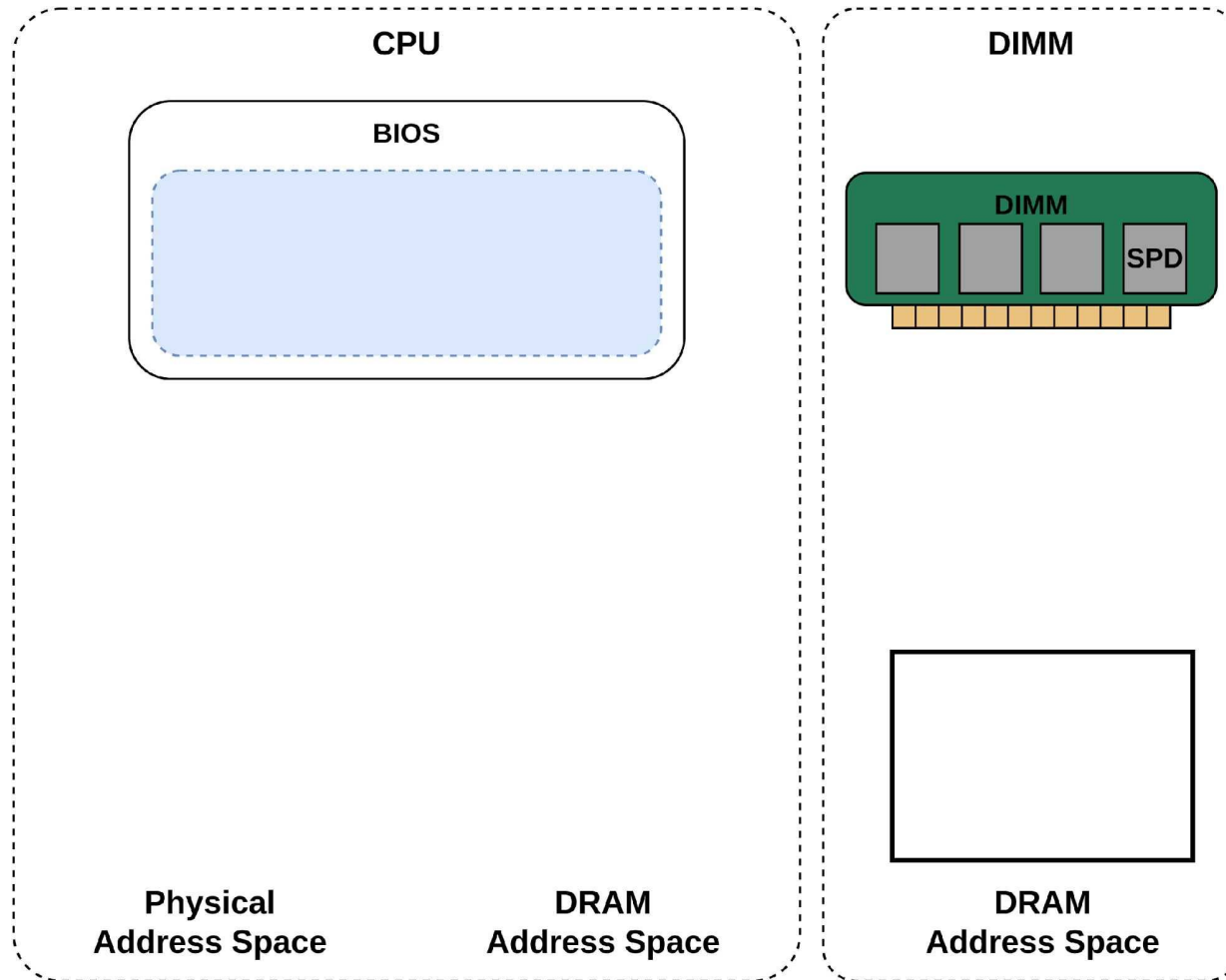

BadRAM: What if Your DRAM Lies to You?

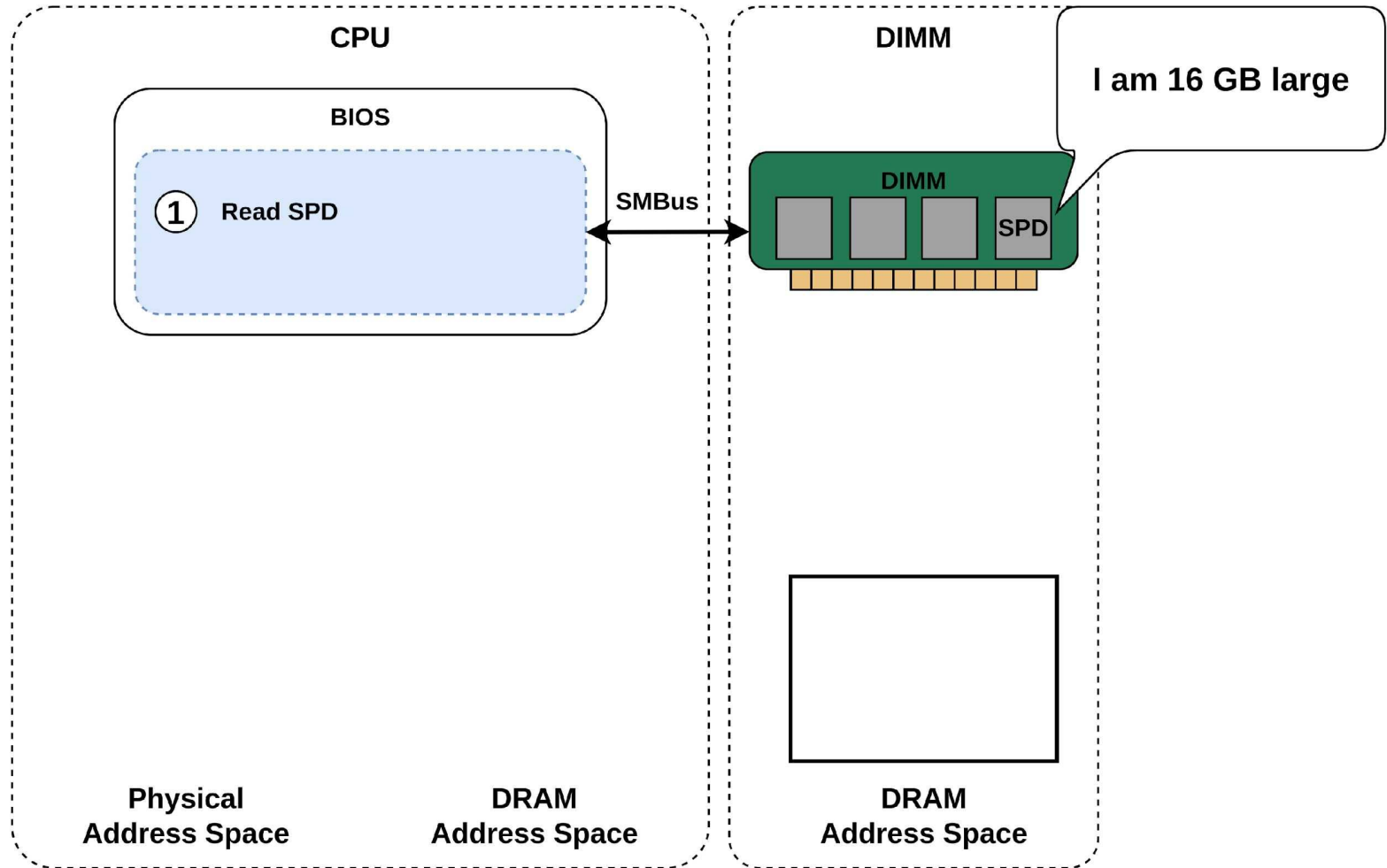

BadRAM: What if Your DRAM Lies to You?

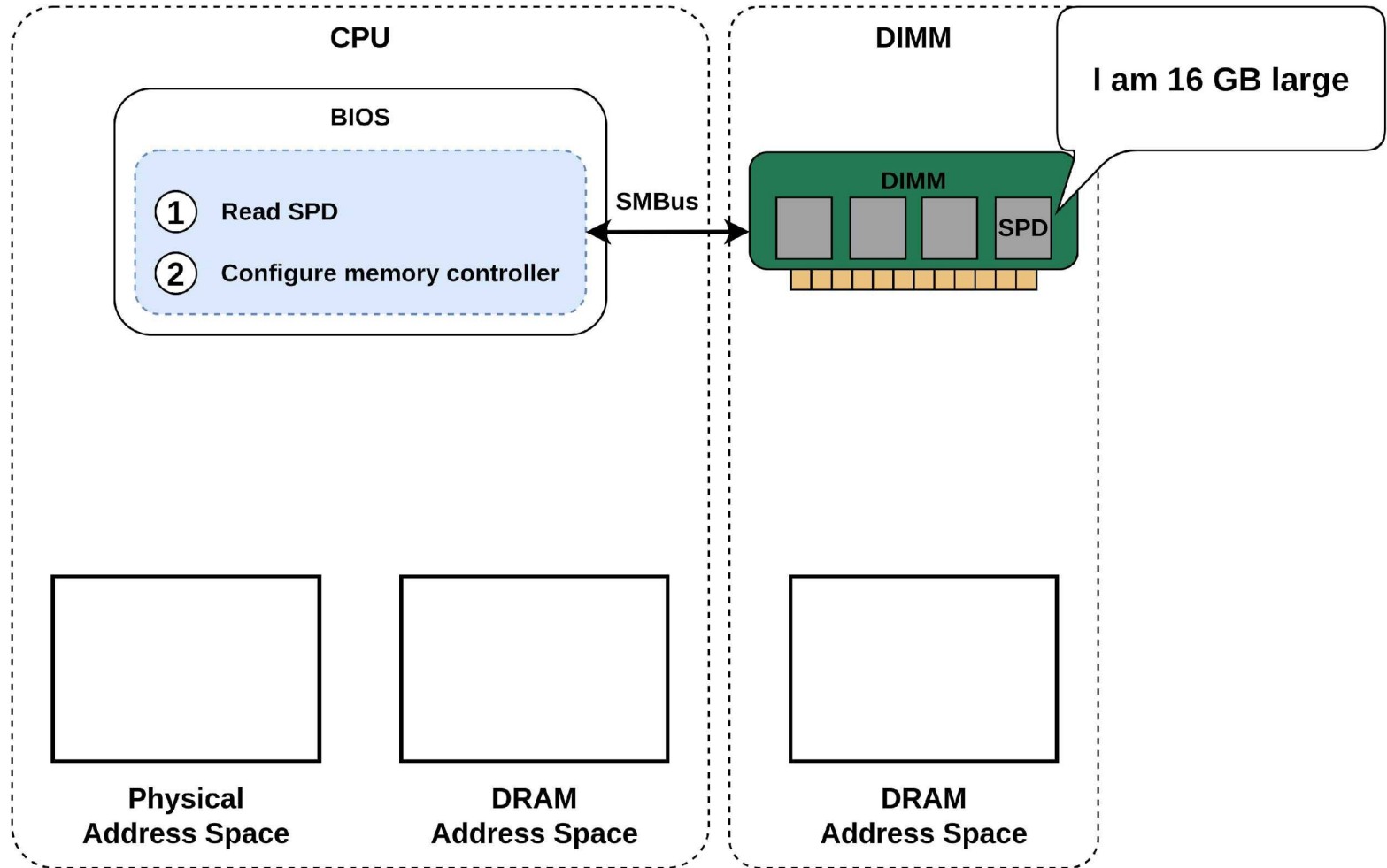

BadRAM: What if Your DRAM Lies to You?

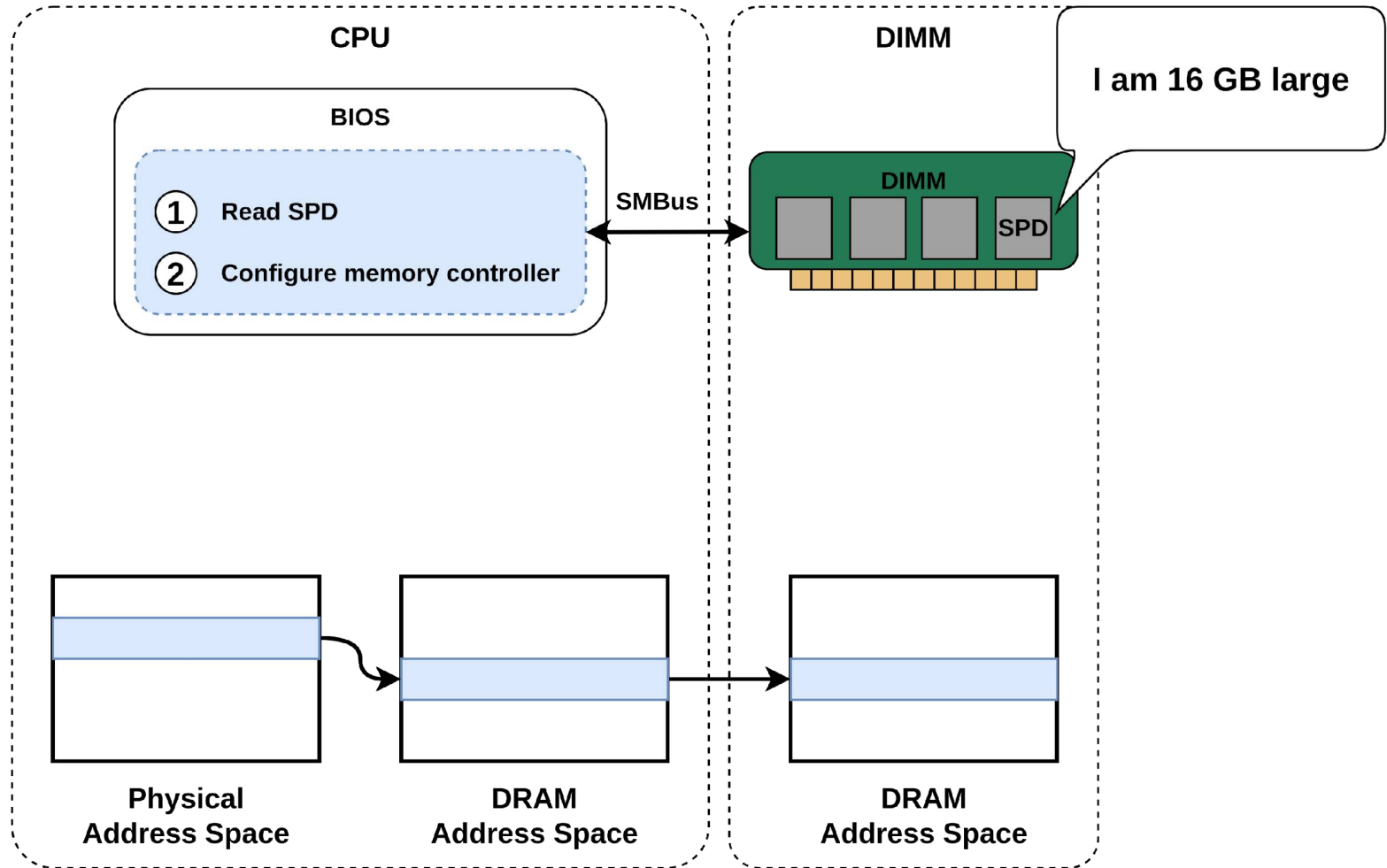

BadRAM: What if Your DRAM Lies to You?

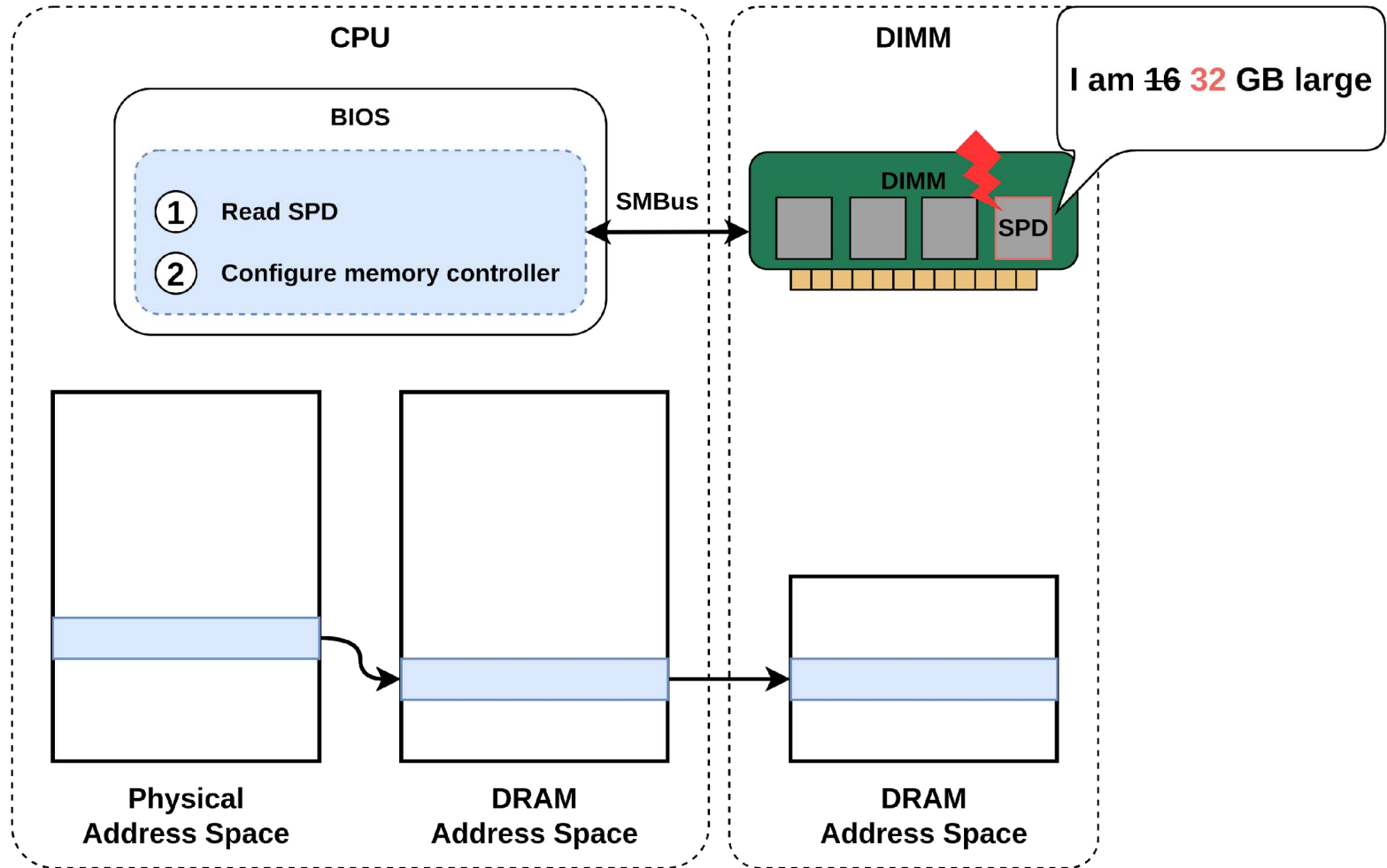

BadRAM: What if Your DRAM Lies to You?

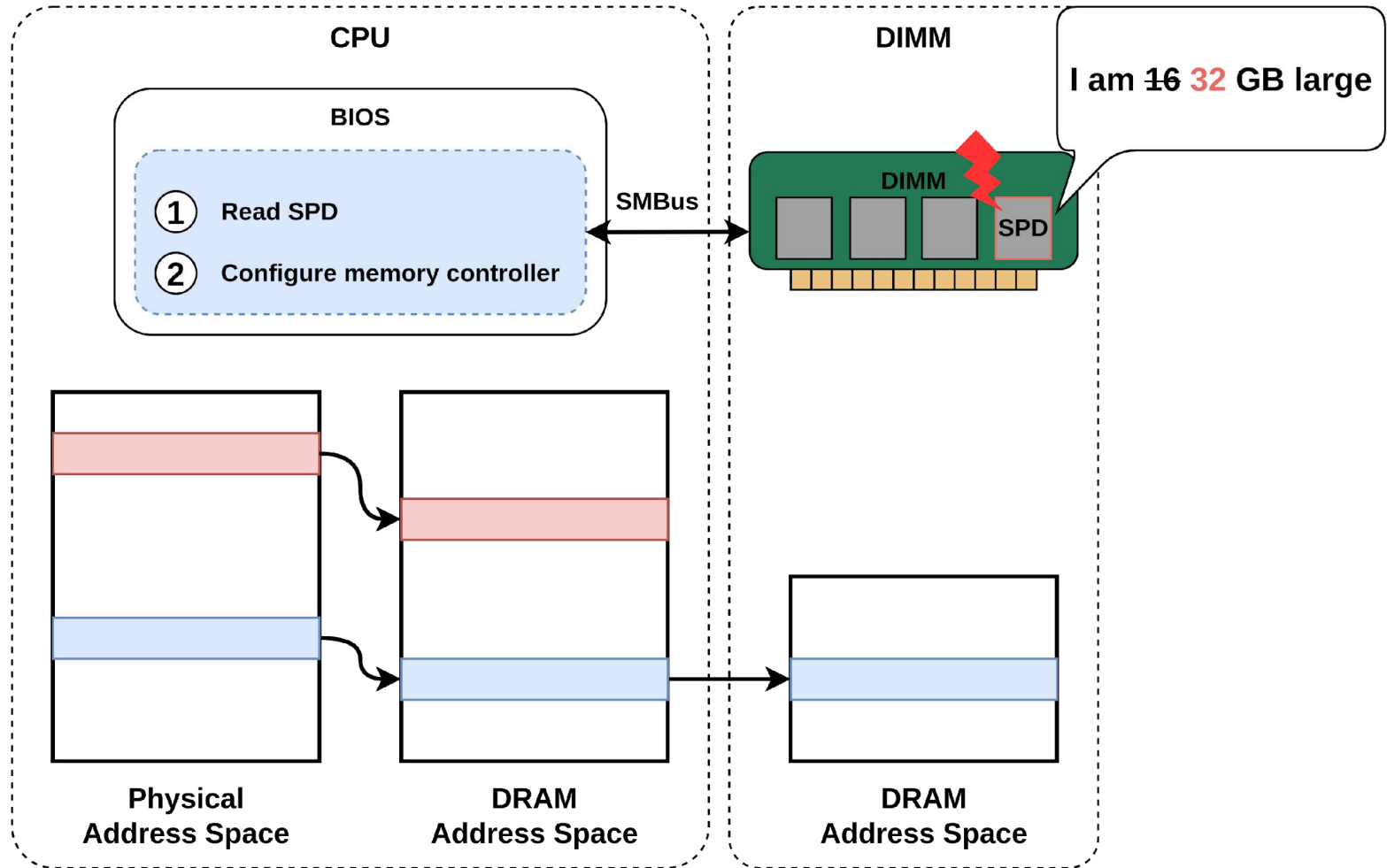

BadRAM: What if Your DRAM Lies to You?

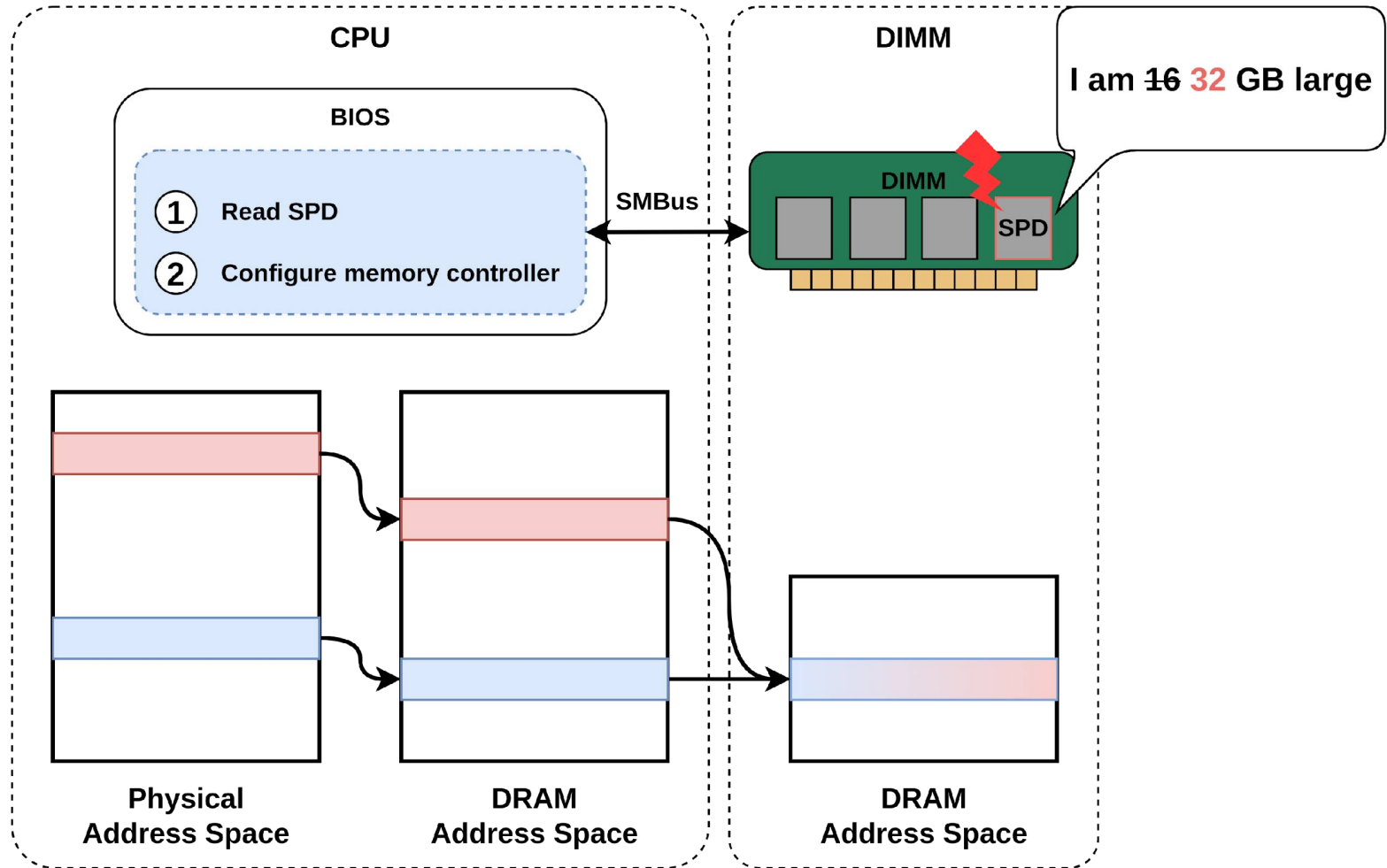

BadRAM: What if Your DRAM Lies to You?

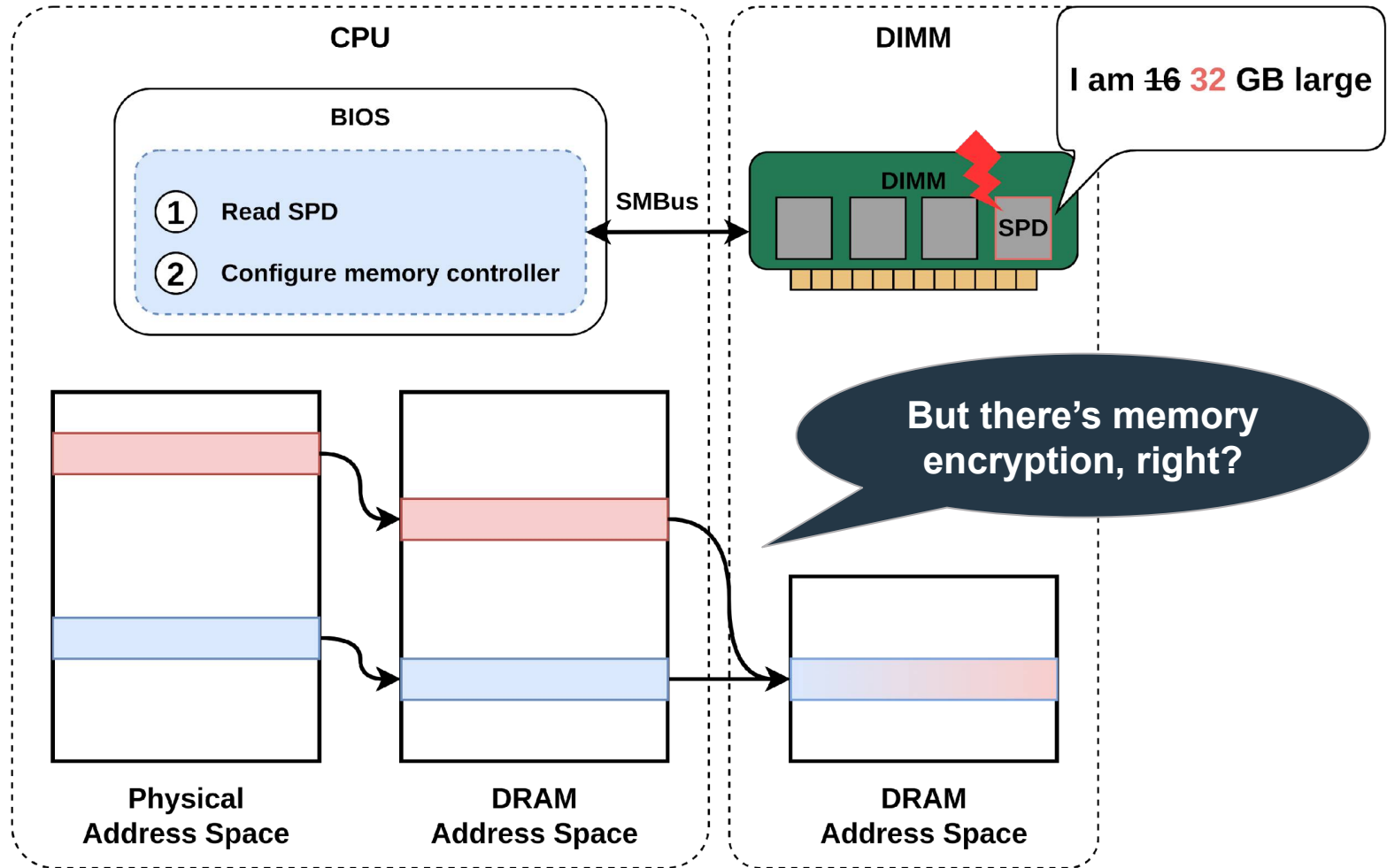

BadRAM: What if Your DRAM Lies to You?

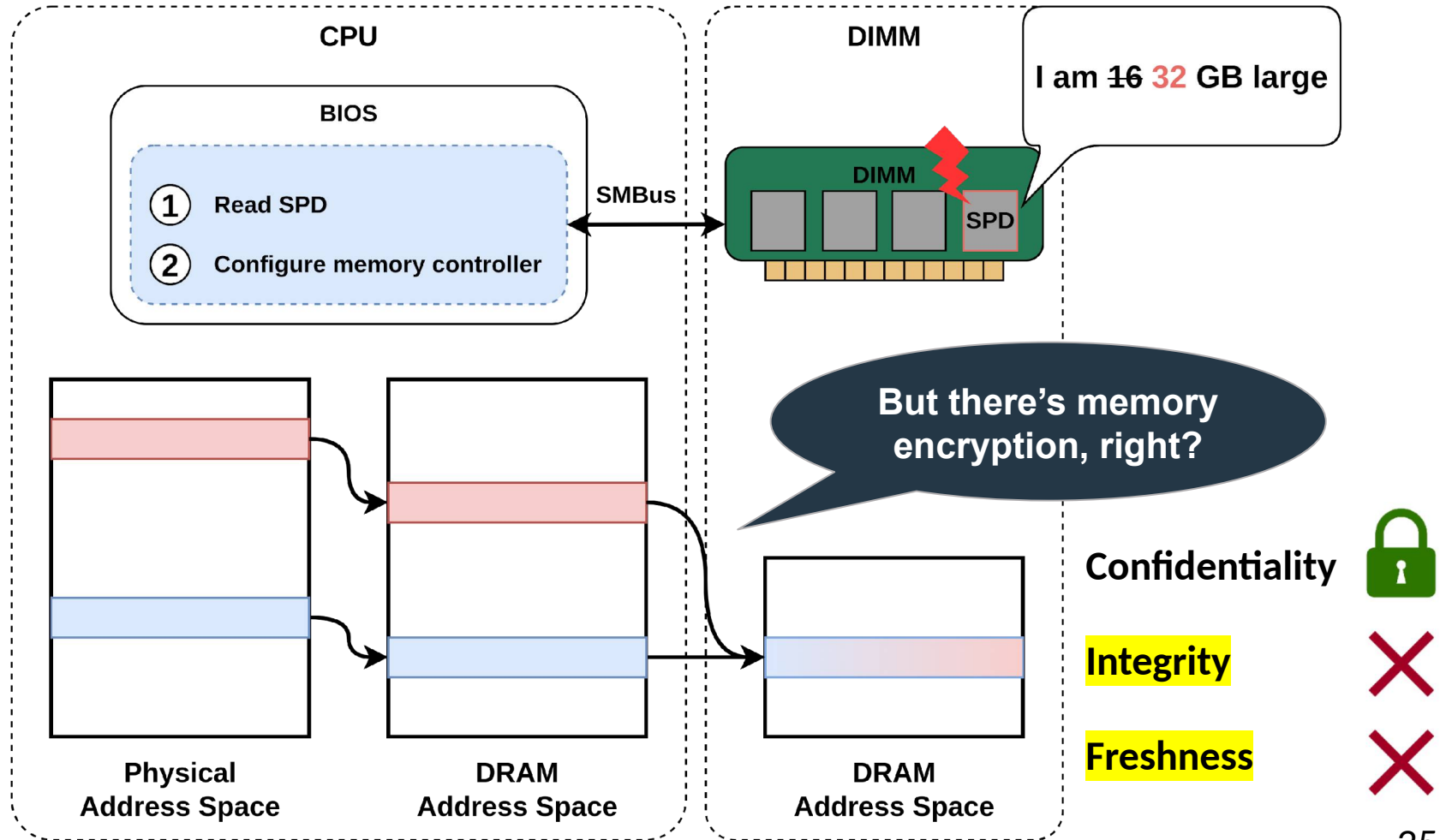

BadRAM: Breaking AMD SEV-SNP Memory Layout Integrity

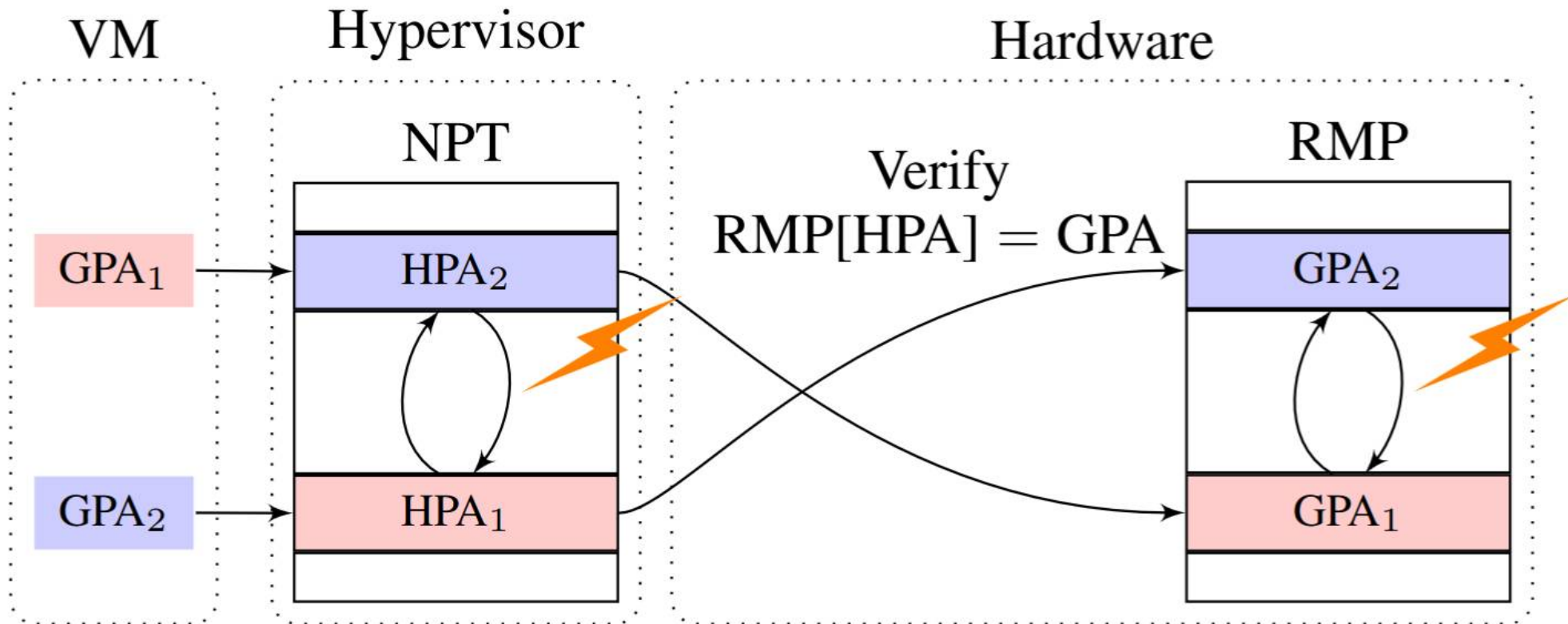

BadRAM: Replaying AMD SEV-SNP Attestation Digest

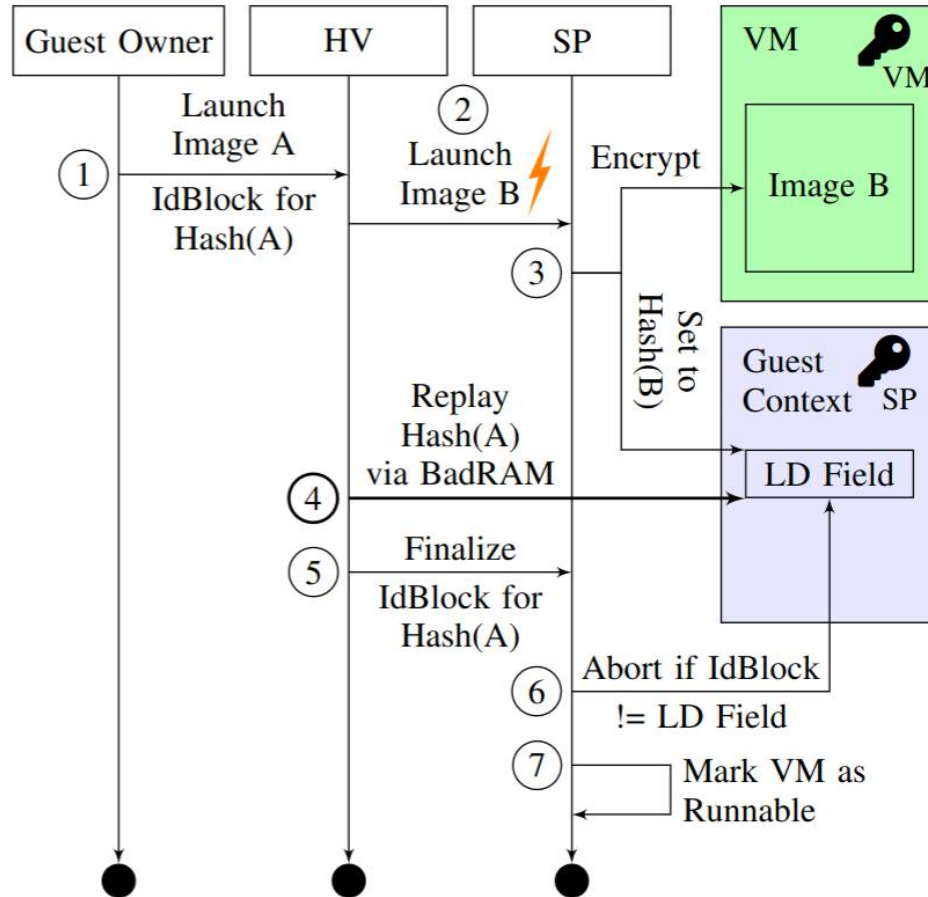



Demo

Replaying encrypted memory

AMD secure VM tech undone by DRAM meddling

Boffins devise BadRAM attack to pilfer secrets from SEV-SNP e

Thomas Claburn

Tue 10 Dec 2024

BadRAM attack breaches AMD secure VMs using a Raspberry Pi Pico, DDR socket, and a 9V battery

News By Mark Tyson published December 11, 2024

AMD has now issued firmware updates for cloud providers.

BEWARE OF GHOSTS

AMD's trusted execution environment blown wide open by new BadRAM attack

Attack bypasses AMD protection promising security, even when a server is compromised.

DAN GOODIN - 10 DEC 2024 18:08 | 112



Credit: Getty Images



BadRAM

Breaching Processor Security via Rogue Memory Modules

Vendor Response: Boot-Time Firmware Mitigations

Undermining Integrity Features of SEV-SNP with Memory Aliasing

AMD ID: AMD-SB-3015

Potential Impact: Loss of Integrity

Severity: Medium

Summary

A team of researchers has reported to AMD that it may be possible to modify serial presence detect (SPD) metadata to make an attached memory module appear larger than it is, potentially allowing an attacker to overwrite physical memory.

Guest Attestation Report [Attestation method for Guest VM]

ATTESTATION_REPORT Structure PLATFORM_INFO field in Byte offset 0h bit 5 contains indication that the mitigation has been applied and confirmed.

Byte Offset	Bits	Name	Description
00h	63:6	-	Reserved.
	5	ALIAS_CHECK_COMPLETE	Indicates that alias detection has completed since the last system reset and there are no aliasing addresses. Resets to 0.



Understanding Memory Aliasing Firmware Mitigations



Idea: Scan for **memory aliases at boot time**

RISC-V implementation:

- Naive detection: 0.753 s



```
for each protected page A do:
  write_mem(A, marker)
  for each page B != A do:
    if read_mem(B) == marker:
      terminate system
    end if
  end for
end for
```

Understanding Memory Aliasing Firmware Mitigations



Idea: Scan for **memory aliases at boot time**

RISC-V implementation:

- Naive detection: 0.753 s
- Opt. detection: 5.687 μ s



```
for each protected page A do:  
  write_mem(A, marker)  
  for each DRAM addr bit i do:  
    B = A ^ i  
    if read_mem(B) == marker:  
      terminate system  
    end if  
  end for  
end for
```

Recap: Memory Initialization - Serial Presence Detect (SPD)

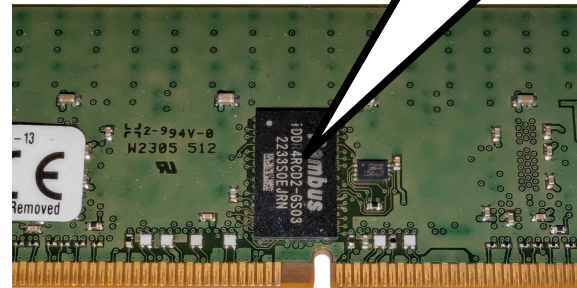
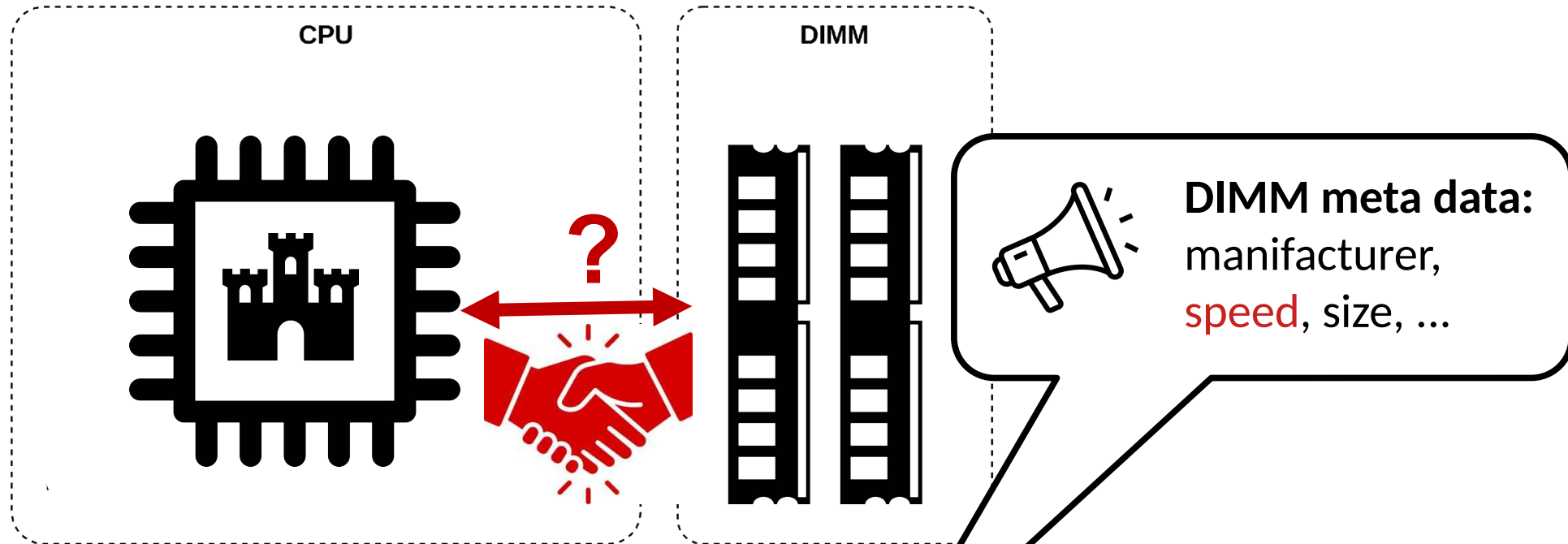

Concurrent Work: Passive Ciphertext Side-Channel Analysis

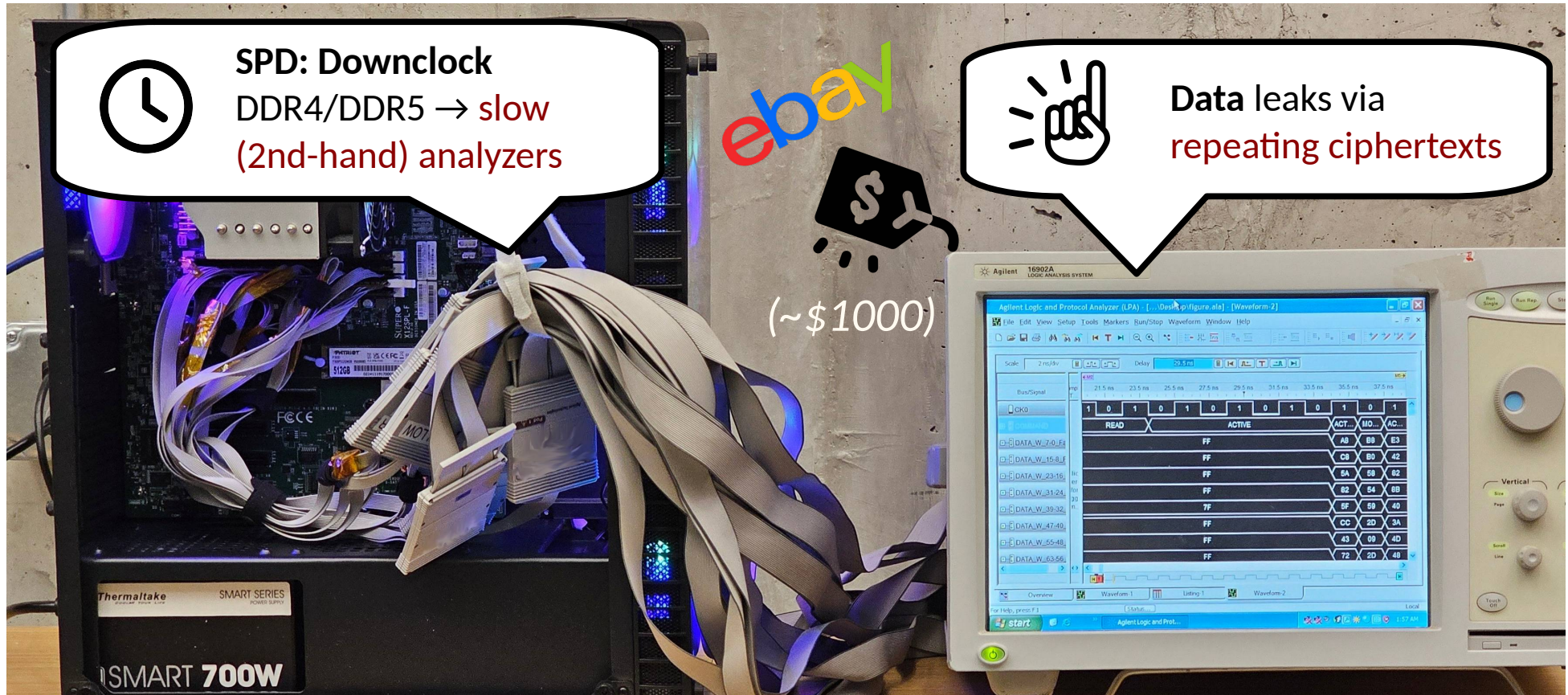

Seto et al. “WireTap: Breaking Server SGX via DRAM Bus Interposition”, CCS 2025.

Chuang et al. “TEE.fail: Breaking Trusted Execution Environments via DDR5 Memory Bus Interposition”, S&P 2026.

Sample Number	Time	Command	Bank Group	Bank	Row	Column	Data	ECC	
-421	-315.800 ns	Refresh	0	0	2	5000	000 FFFF FFFF FFFF FFFF	FF	
-420	-315.050 ns	Refresh	0	0	2	5000	000 FFFF FFFF FFFF FFFF	FF	
-19	-14.275 ns	Active	0	1	2	7828	028 FFFF FFFF FFFF FFFF	FF	Plaintext Data
-18	-13.525 ns	Active	0	1	2	7828	028 FFFF FFFF FFFF FFFF	FF	
-1	-750 ps	Write	0	1	3	1000	000 FFFF FFFF FFFF FFFF	FF	
0	0 s	Write	0	1	3	1000	000 FFFF FFFF FFFF FFFF	FF	
23	17.225 ns	Active	1	0	2	EAB0	2B0 866A 8507 FCBA 1F54	C9	0000 0000 0000 0000
24	17.975 ns	Active	1	3	3	EEB0	2B0 1B11 E884 BCEE 727D	A2	0000 0000 0000 0000
25	18.725 ns	Active	1	0	2	EEB0	2B0 DB82 163F E37F 8A24	CA	0000 0000 0000 0000
26	19.475 ns	Active	1	0	2	EEB0	2B0 24D8 AFB5 D817 8964	5D	0000 0000 0000 0000
27	20.225 ns	Active	1	2	2	EEB0	2B0 91E9 2ECE D0D6 E7AB	69	0000 0000 0000 0000
28	20.975 ns	Active	1	0	2	EEB0	2B0 3E95 DEBA 11C5 38FA	8C	0000 0000 0000 0000
29	21.725 ns	Active	3	2	2	EEB0	2B0 CCC8 7C68 83A4 2F06	E0	0000 0000 0000 0000
30	22.475 ns	Active	1	2	2	EEB0	2B0 15A0 9DFE E856 42DE	C7	0000 0000 0000 0000
305	228.725 ns	Write	0	1	3	1000	000 FFFF FFFF FFFF FFFF	FF	
306	229.475 ns	Write	0	1	3	1000	000 FFFF FFFF FFFF FFFF	FF	
329	246.700 ns	Active	1	0	2	EAB0	2B0 D53C DD3A 96C3 79B4	69	ffff ffff ffff ffff
330	247.450 ns	Active	1	0	2	EAB0	2B0 ED83 3E61 4C2F C1BB	4E	ffff ffff ffff ffff
331	248.200 ns	Active	1	2	2	EEB0	2B0 D9C0 95CC 3C6F 1A40	95	ffff ffff ffff ffff
332	248.950 ns	Active	1	0	2	EEB0	2B0 1642 CC09 8021 0543	EF	ffff ffff ffff ffff
333	249.700 ns	Active	1	0	2	EAB0	2B0 B3B7 9A51 C2E8 699A	70	ffff ffff ffff ffff
334	250.450 ns	Active	3	2	2	EEB0	2B0 A714 F154 511D DFD2	64	ffff ffff ffff ffff
335	251.225 ns	Active	1	0	2	EAB0	2B0 5D99 6FDA 8458 EB88	47	ffff ffff ffff ffff
336	251.975 ns	Active	3	3	3	FEB0	2B0 2716 4D64 0675 5761	D5	ffff ffff ffff ffff
629	471.575 ns	Write	0	1	3	1000	000 FFFF FFFF FFFF FFFF	FF	
630	472.325 ns	Write	0	1	3	1000	000 FFFF FFFF FFFF FFFF	FF	
653	489.600 ns	Active	1	0	2	EAB0	2B0 866A 8507 FCBA 1F54	C9	0000 0000 0000 0000
654	490.350 ns	Active	1	3	2	EEB0	2B0 1B11 E884 BCEE 727D	A2	0000 0000 0000 0000
655	491.125 ns	Active	1	2	2	EEB0	2B0 DB82 163F E37F 8A24	CA	0000 0000 0000 0000
656	491.875 ns	Active	1	0	2	EEB0	2B0 24D8 AFB5 D817 8964	5D	0000 0000 0000 0000
657	492.625 ns	Active	1	2	2	EEB0	2B0 91E9 2ECE D0D6 E7AB	69	0000 0000 0000 0000
658	493.375 ns	Active	1	0	2	EEB0	2B0 3E95 DEBA 11C5 38FA	8C	0000 0000 0000 0000
659	494.125 ns	Active	1	2	2	EEB0	2B0 CCC8 7C68 83A4 2F06	E0	0000 0000 0000 0000
660	494.875 ns	Active	1	2	2	EEB0	2B0 15A0 9DFE E856 42DE	C7	0000 0000 0000 0000
853	639.700 ns	Active	2	1	2	5651	251 FFFF FFFF FFFF FFFF	FF	
854	640.450 ns	Active	2	1	2	5651	251 FFFF FFFF FFFF FFFF	FF	
871	653.175 ns	Read	2	1	3	52A0	2A0 FFFF FFFF FFFF FFFF	FF	



Idea #2: Low-Cost Active Interposer

Recap: Boot-Time Firmware Mitigations

Undermining Integrity Features of SEV-SNP with Memory Aliasing

AMD ID: AMD-SB-3015

Potential Impact: Loss of Integrity

Severity: Medium

Summary

A team of researchers has reported to AMD that it may be possible to modify serial presence detect (SPD) metadata to make an attached memory module appear larger than it is, potentially allowing an attacker to overwrite physical memory.

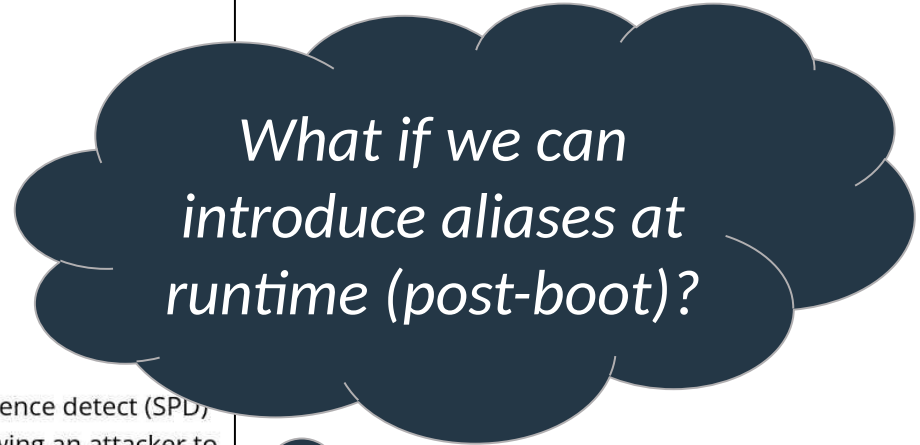

Guest Attestation Report [Attestation method for Guest VM]

ATTESTATION_REPORT Structure PLATFORM_INFO offset 0h bit 5 contains indication that the mitigation has been applied and confirmed.



Byte Offset	Bits	Name	
00h	63:6	-	Reserved
	5	ALIAS_CHECK_COMPLETE	Indicates that alias detection has completed since the last system reset and there are no aliasing addresses. Resets to 0.



A white cat with striking green eyes is the central focus of the image. The cat is looking directly at the camera with a neutral, somewhat intense expression. The background is a blurred outdoor setting with a brick-paved ground and some greenery. The text is overlaid on the image in a bold, white, sans-serif font with a black outline.

I HAVE...

AN EVIL PLAN

Interfering at Runtime: Commercial DRAM Interposers?



Genuine New MW-Keysight U4972A DDR4 Protocol Debugging and Analysis Solution Logic Analyzers Factory Wholesale Price

US\$782,016.00

1 Set (MOQ)

Send Inquiry

Chat Now

Product Details

Customization:	Available
After-sales Service:	12 Months
Warranty:	12 Months



Shenzhen Leading International Trading Co., Ltd. >

Gold Member Since 2024

Audited Supplier



Idea: Tampering with Addressing at Runtime

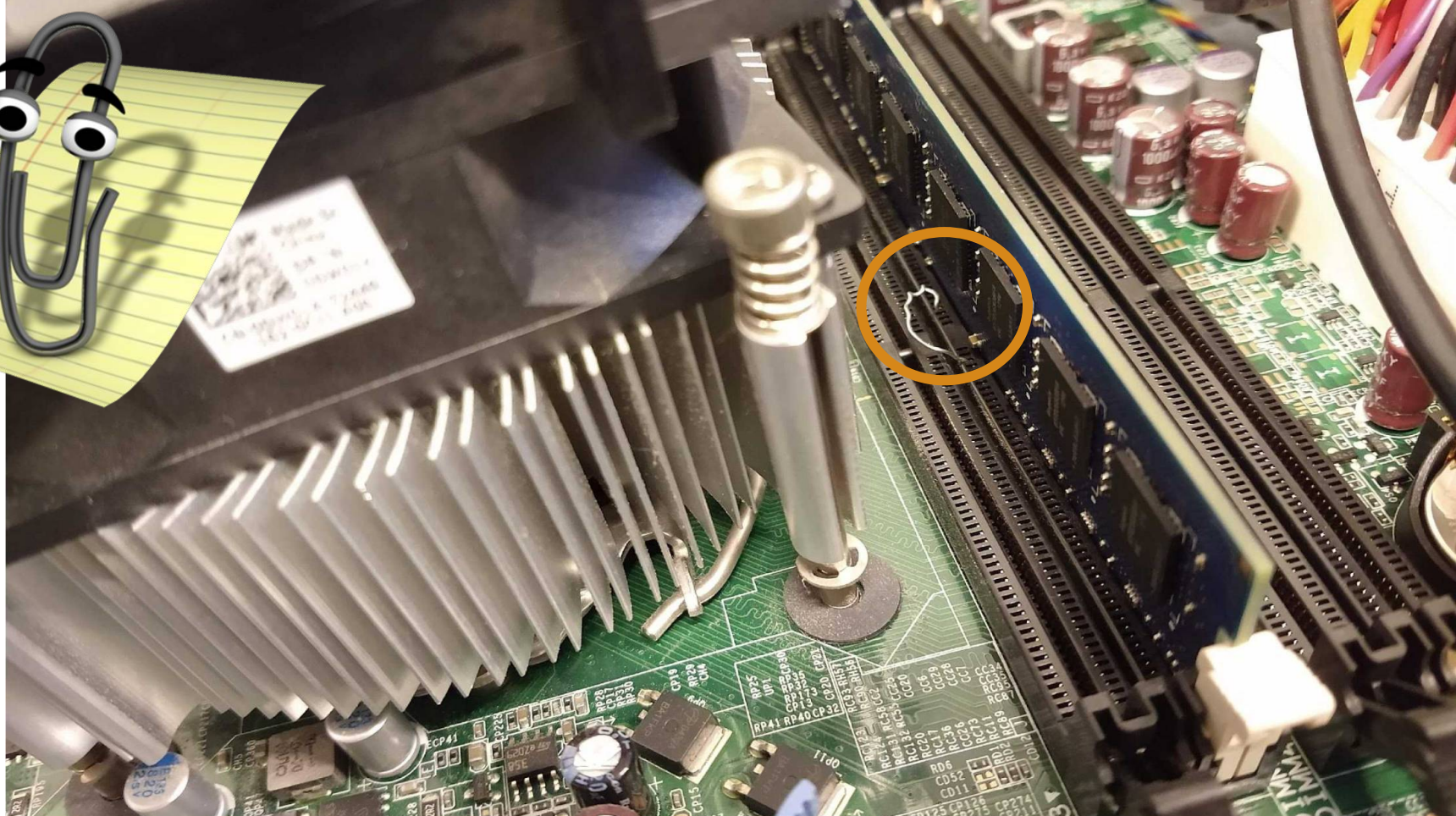

Idea: Tampering with Addressing at Runtime

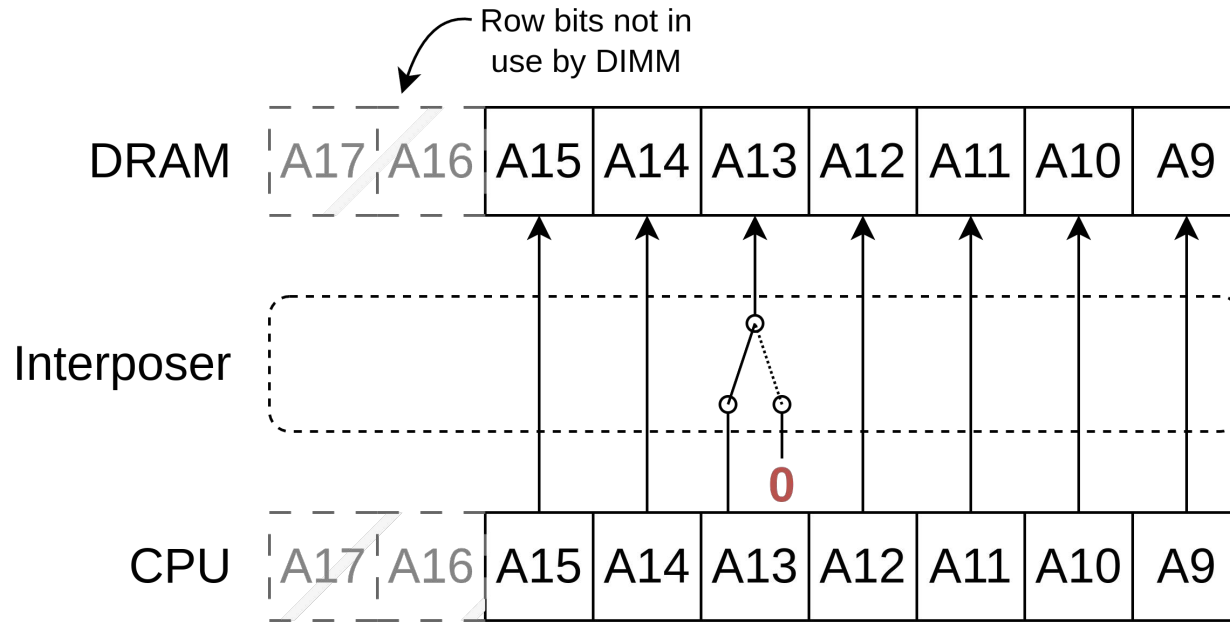

- Boot time: **Inactive**
 - Passes checks

Idea: Tampering with Addressing at Runtime

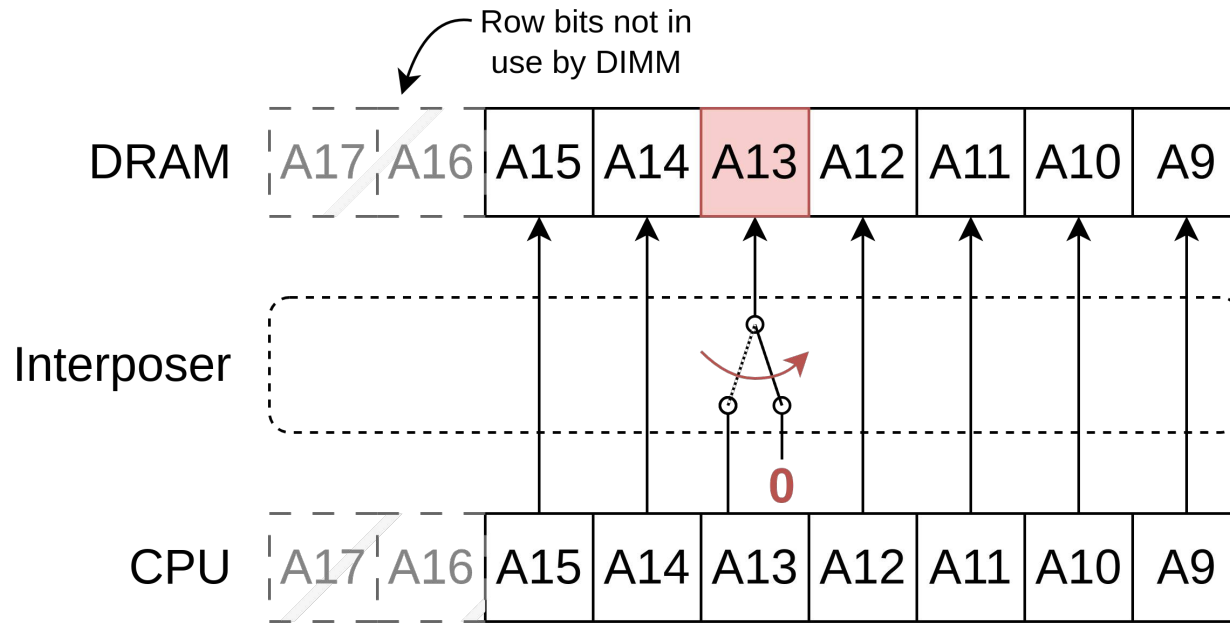

- Boot time: **Inactive**
 - Passes checks
- Attack: **Active**
 - Dynamically switch to GND

Battering RAM: Fifty Dollars to Root the Cloud

Microcontroller (RPI Pico) \$4

DDR4 connector: \$16

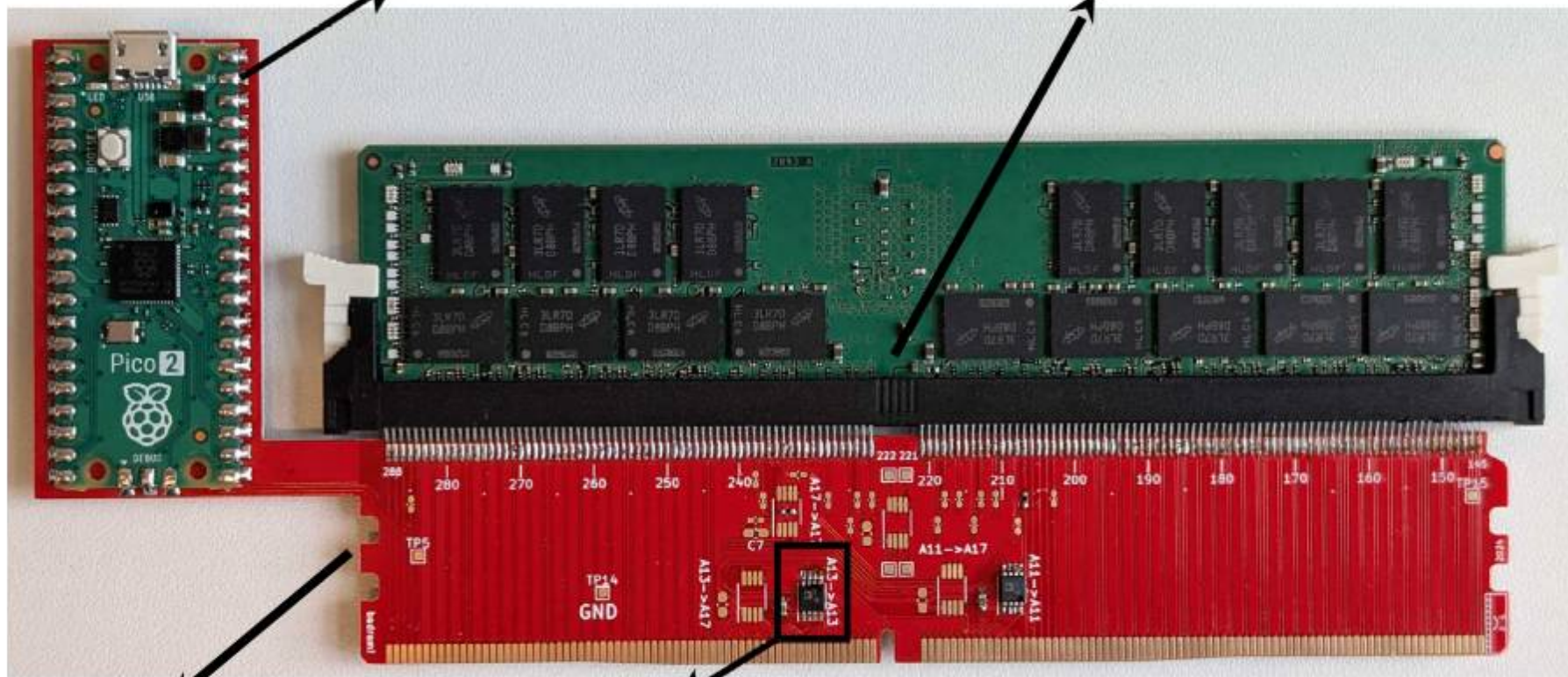

Custom PCB: \$18

Analog Switch (ADG902) \$4

Battering RAM: Dynamically Introducing Aliases

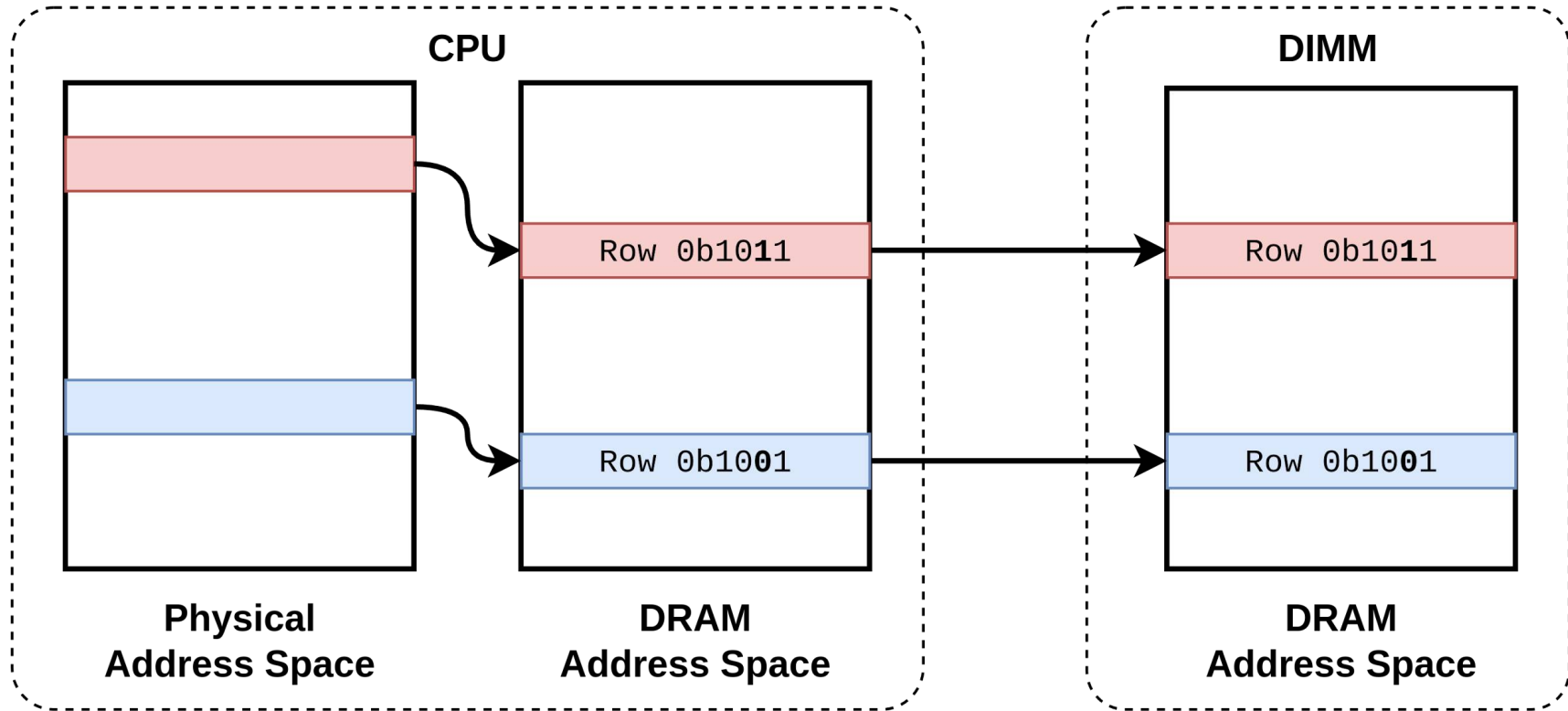

Battering RAM: Dynamically Introducing Aliases

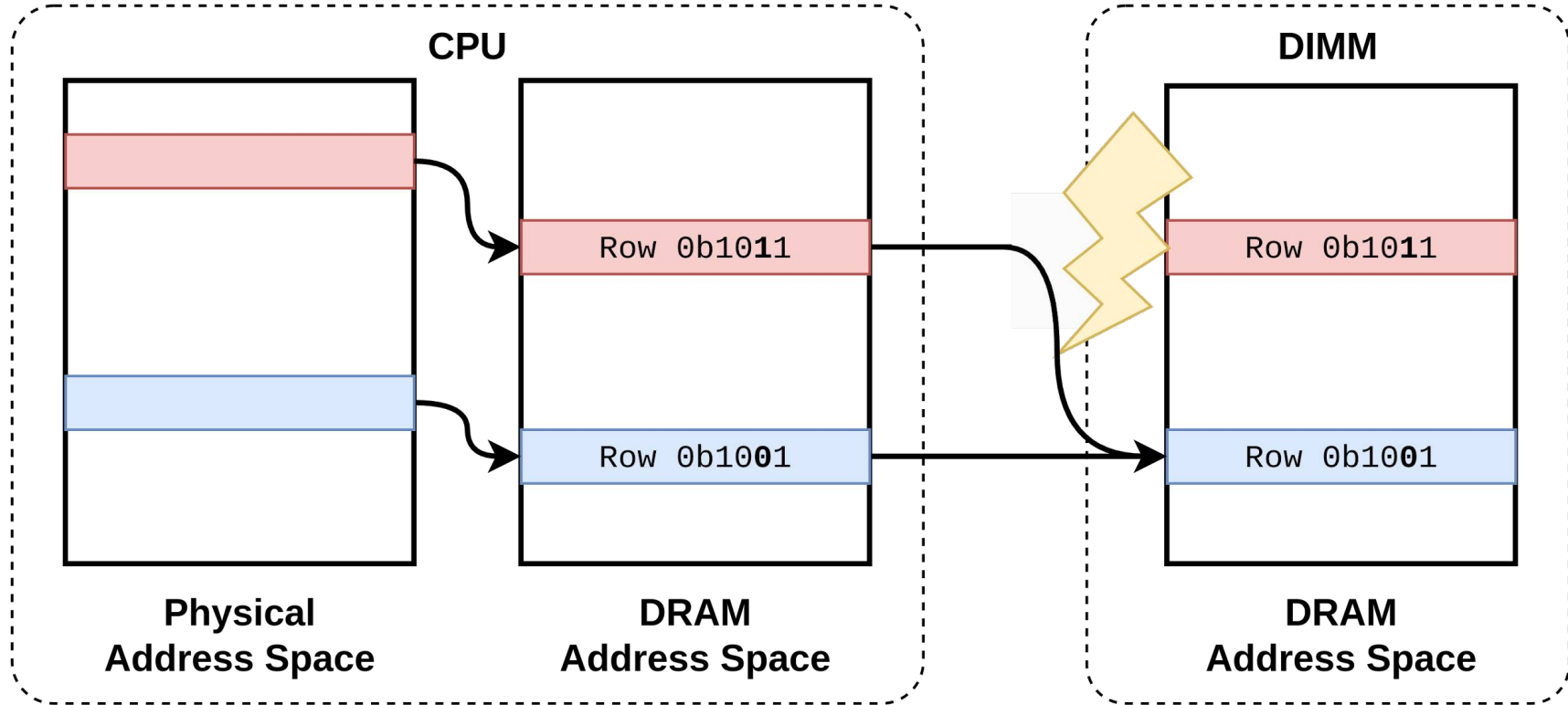

Battering RAM: Breaking Intel Scalable SGX Memory Encryption

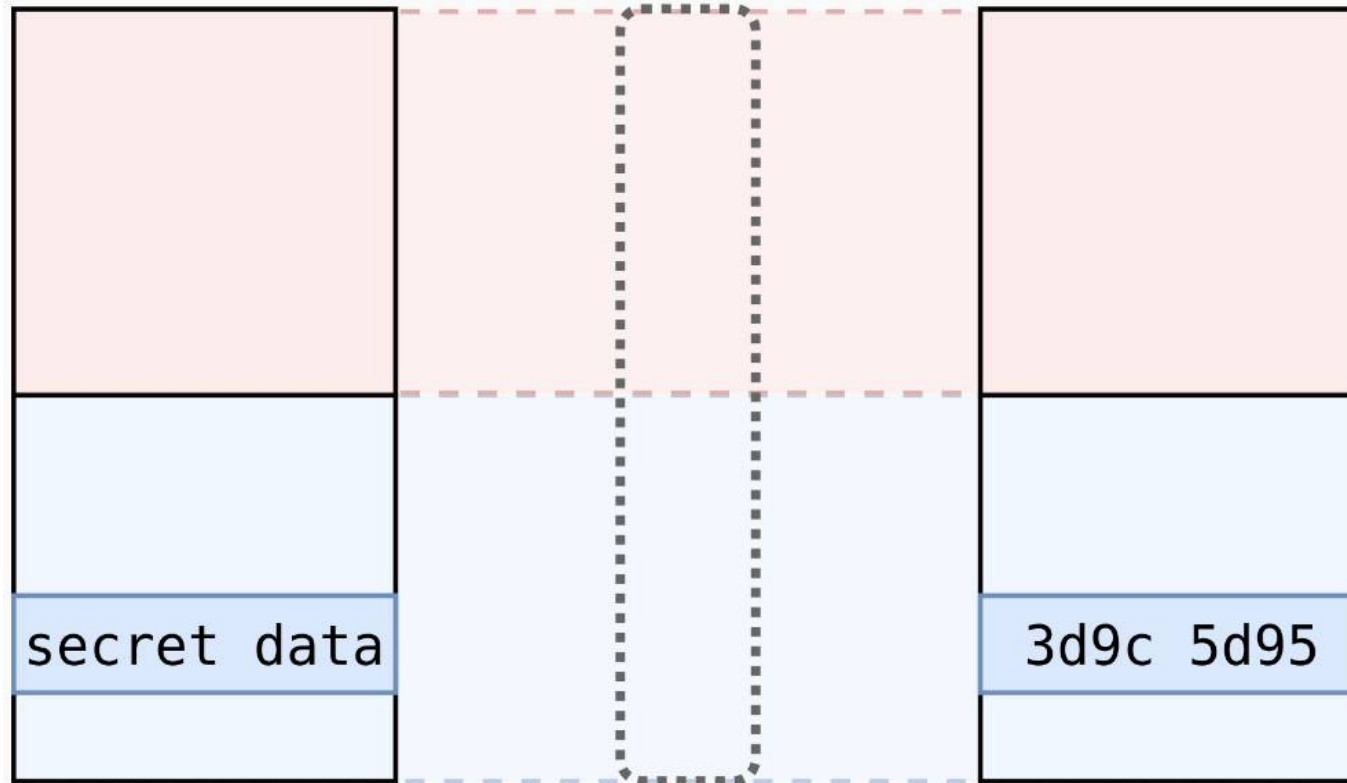

Battering RAM: Breaking Intel Scalable SGX Memory Encryption

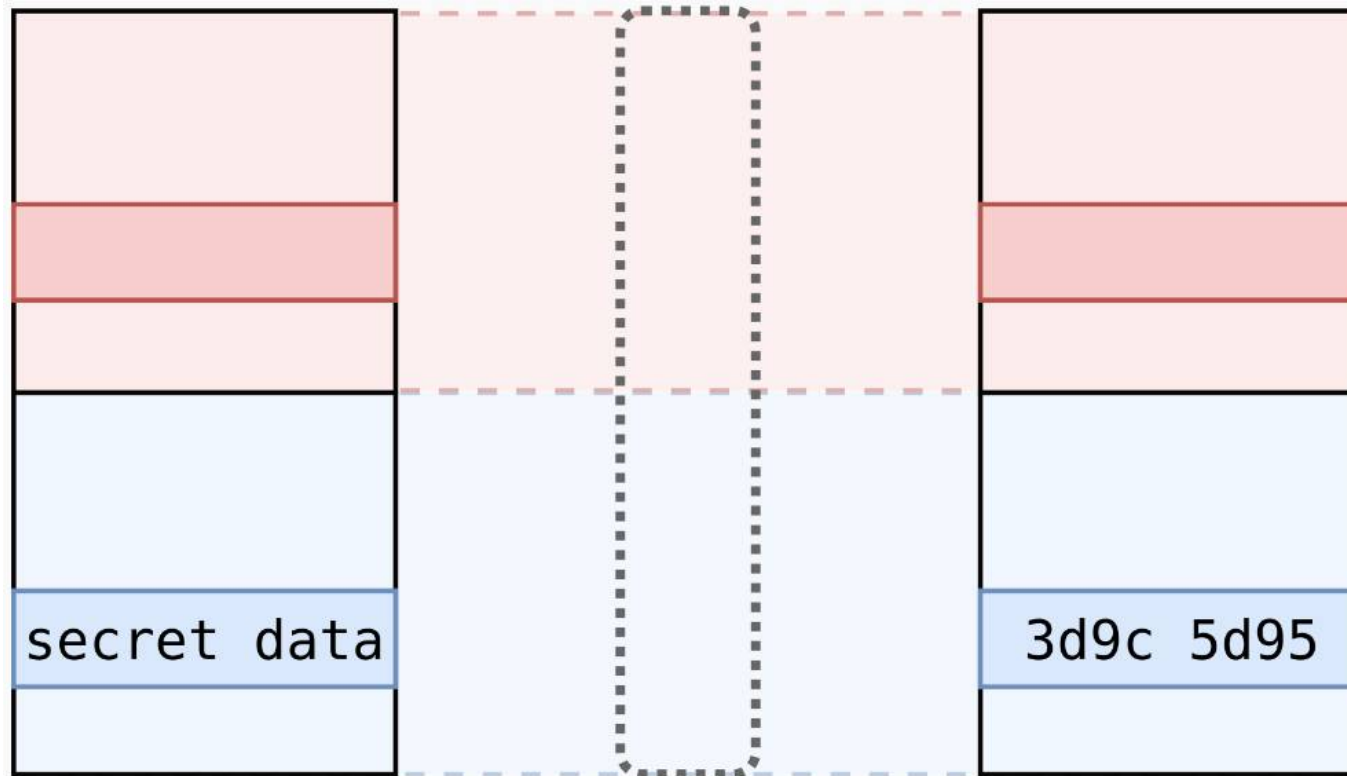

Battering RAM: Breaking Intel Scalable SGX Memory Encryption

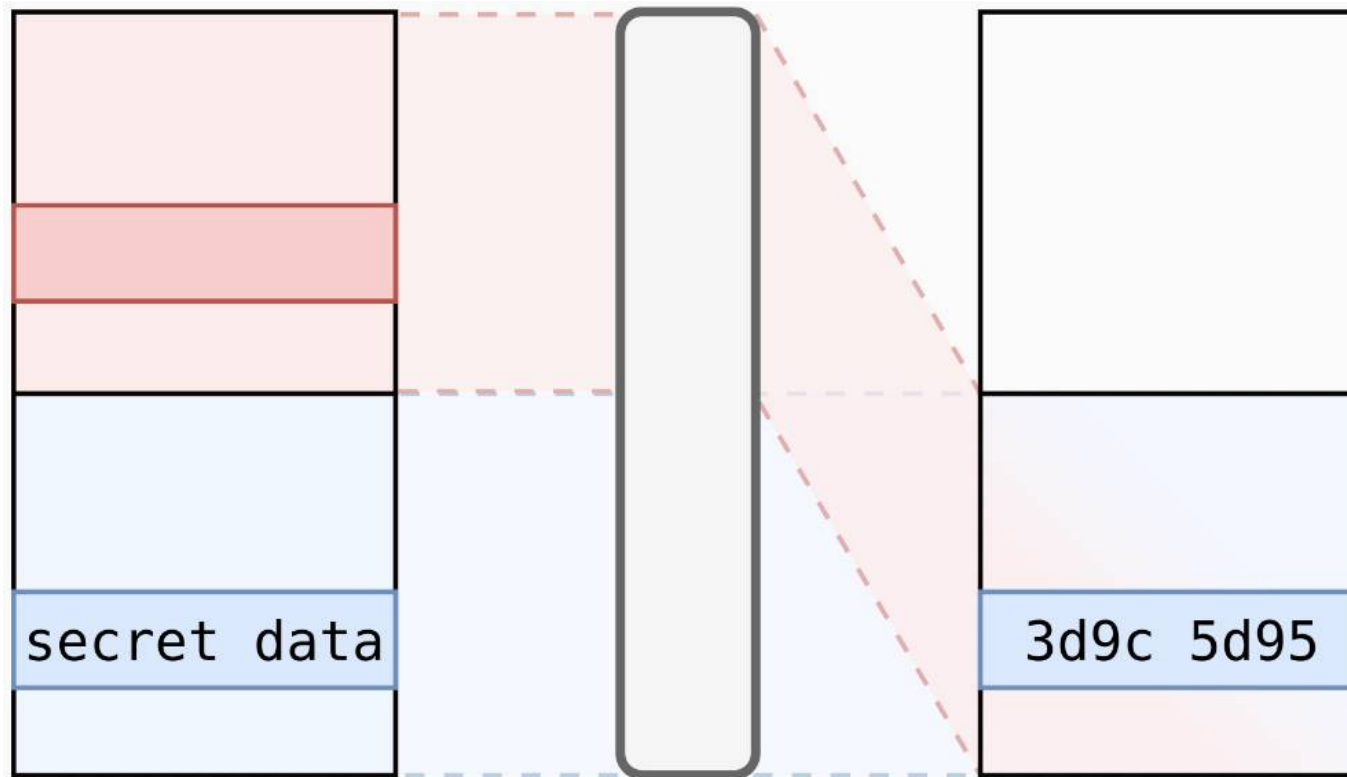

Battering RAM: Breaking Intel Scalable SGX Memory Encryption

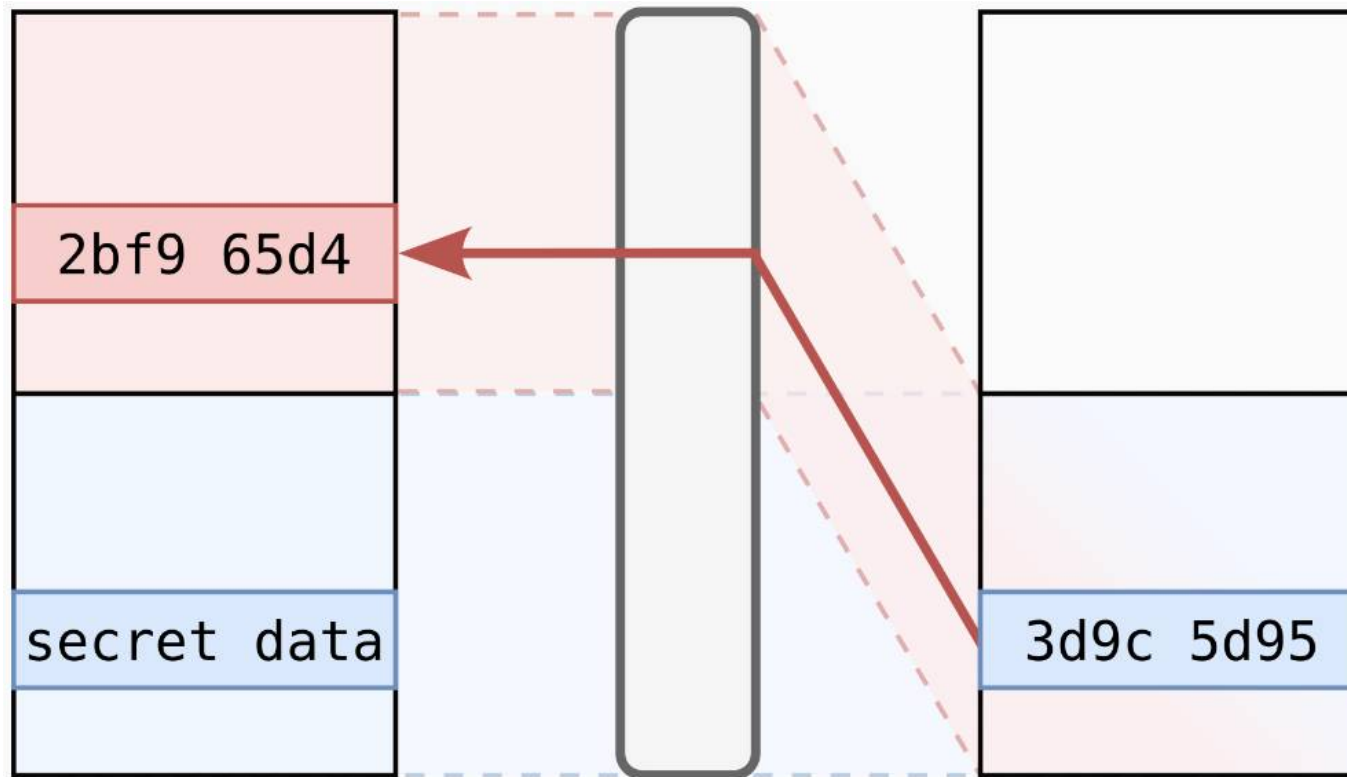

Battering RAM: Breaking Intel Scalable SGX Memory Encryption

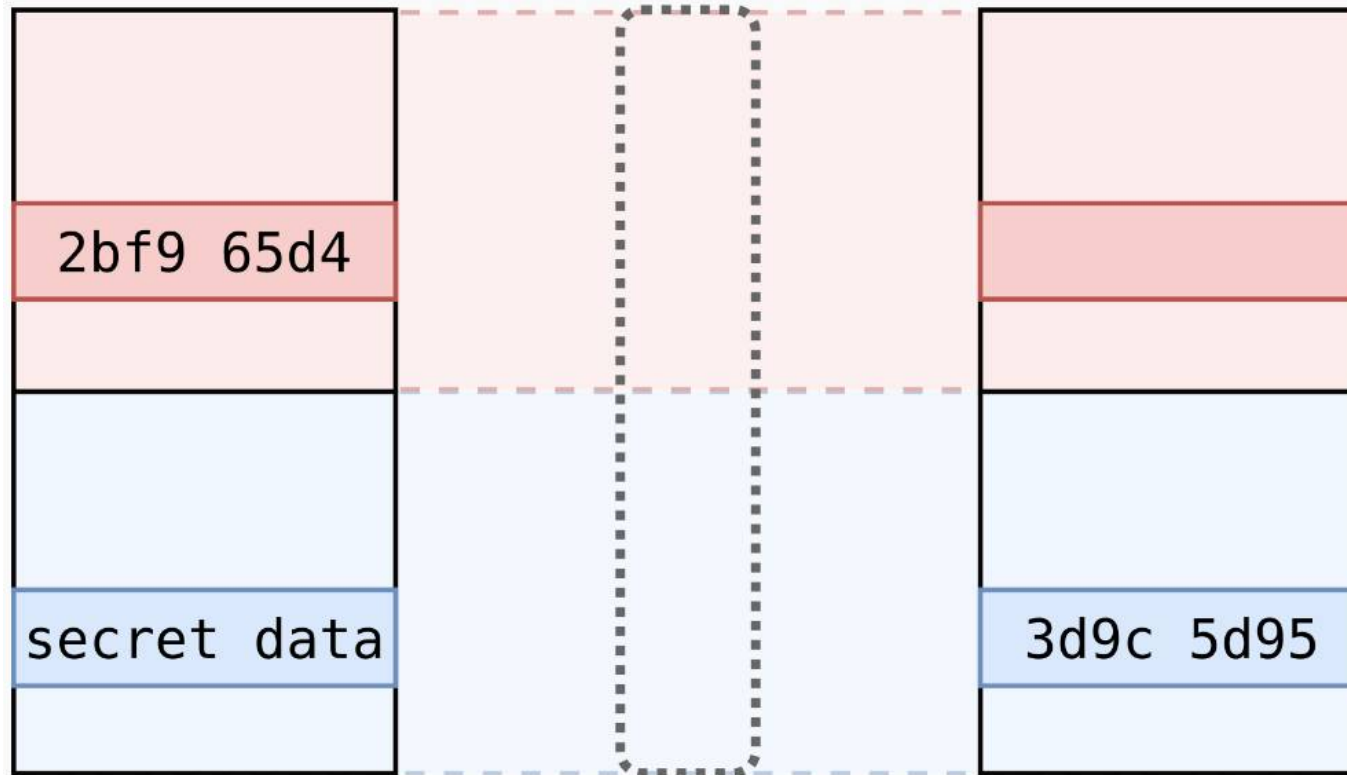

Battering RAM: Breaking Intel Scalable SGX Memory Encryption

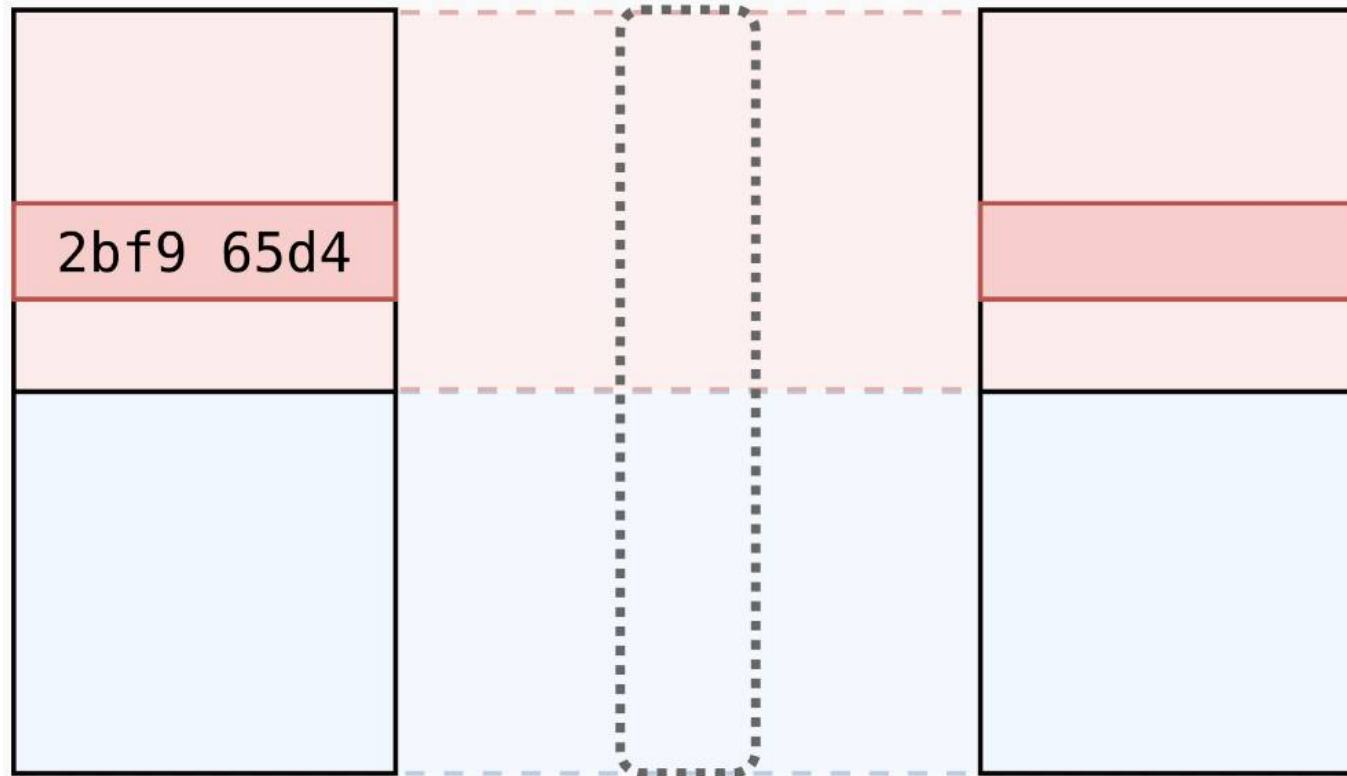

Battering RAM: Breaking Intel Scalable SGX Memory Encryption

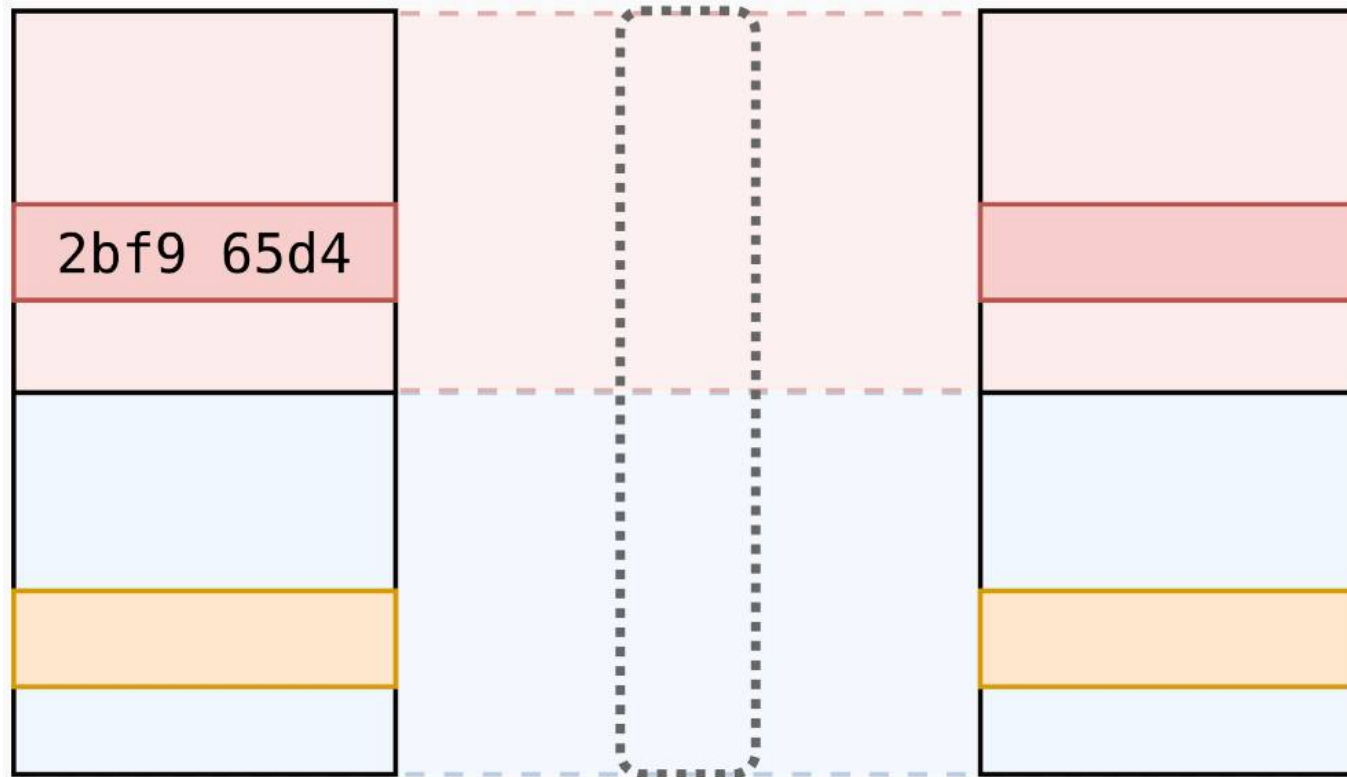

Battering RAM: Breaking Intel Scalable SGX Memory Encryption

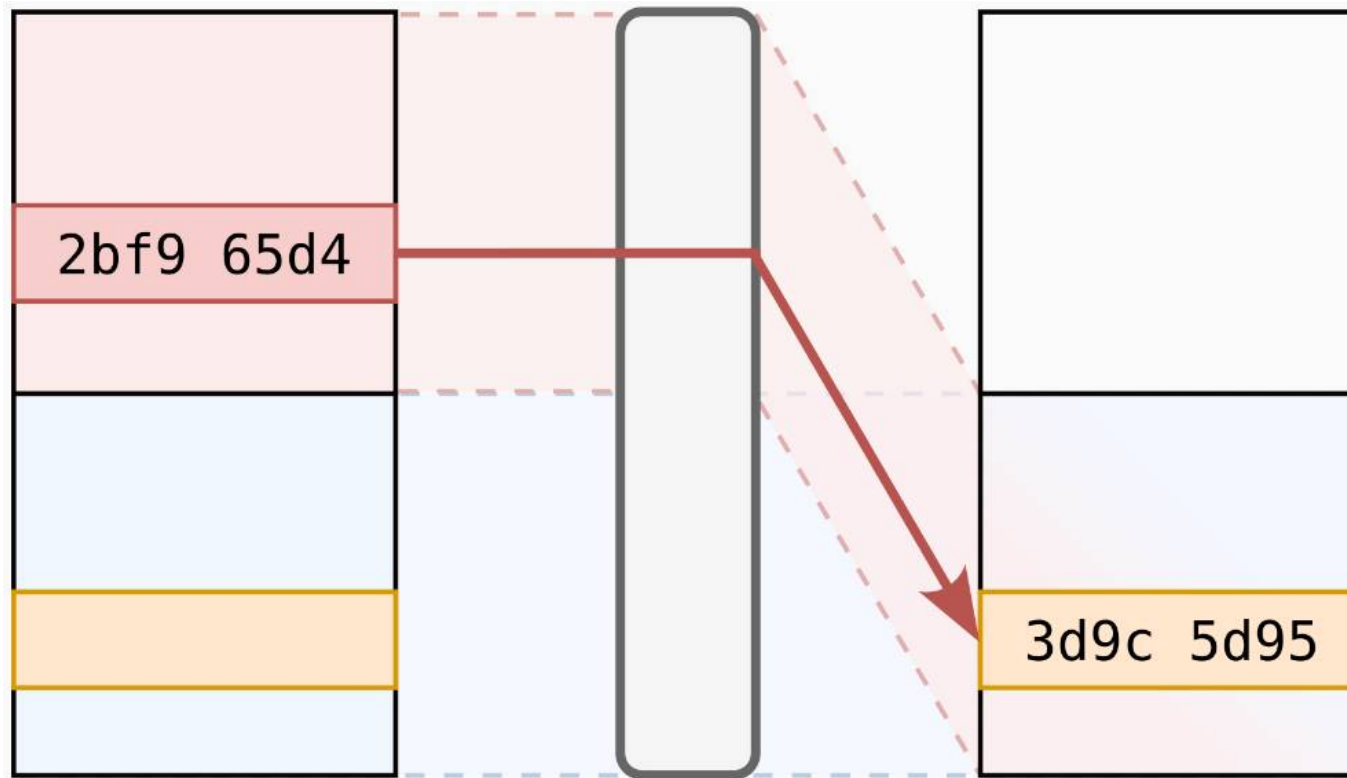

Battering RAM: Breaking Intel Scalable SGX Memory Encryption

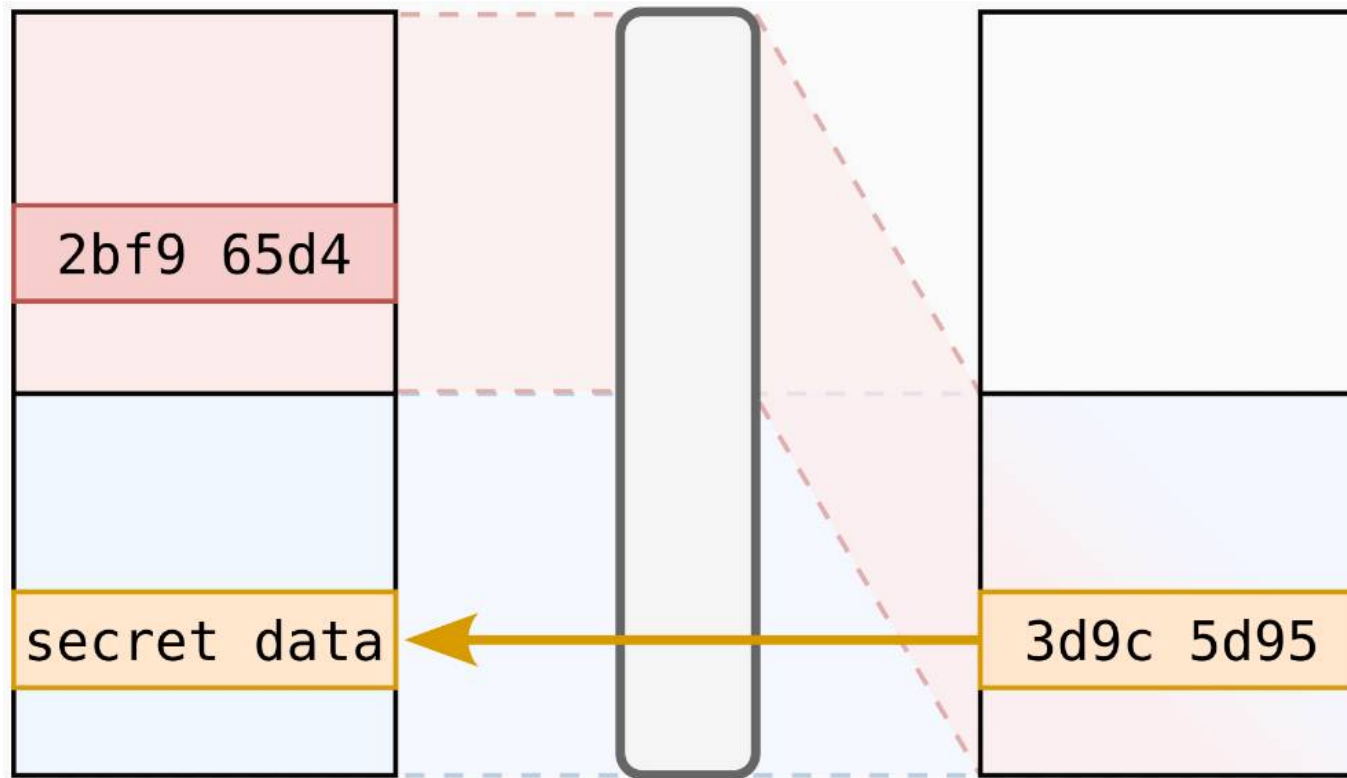

Battering RAM: Breaking Intel Scalable SGX Memory Encryption

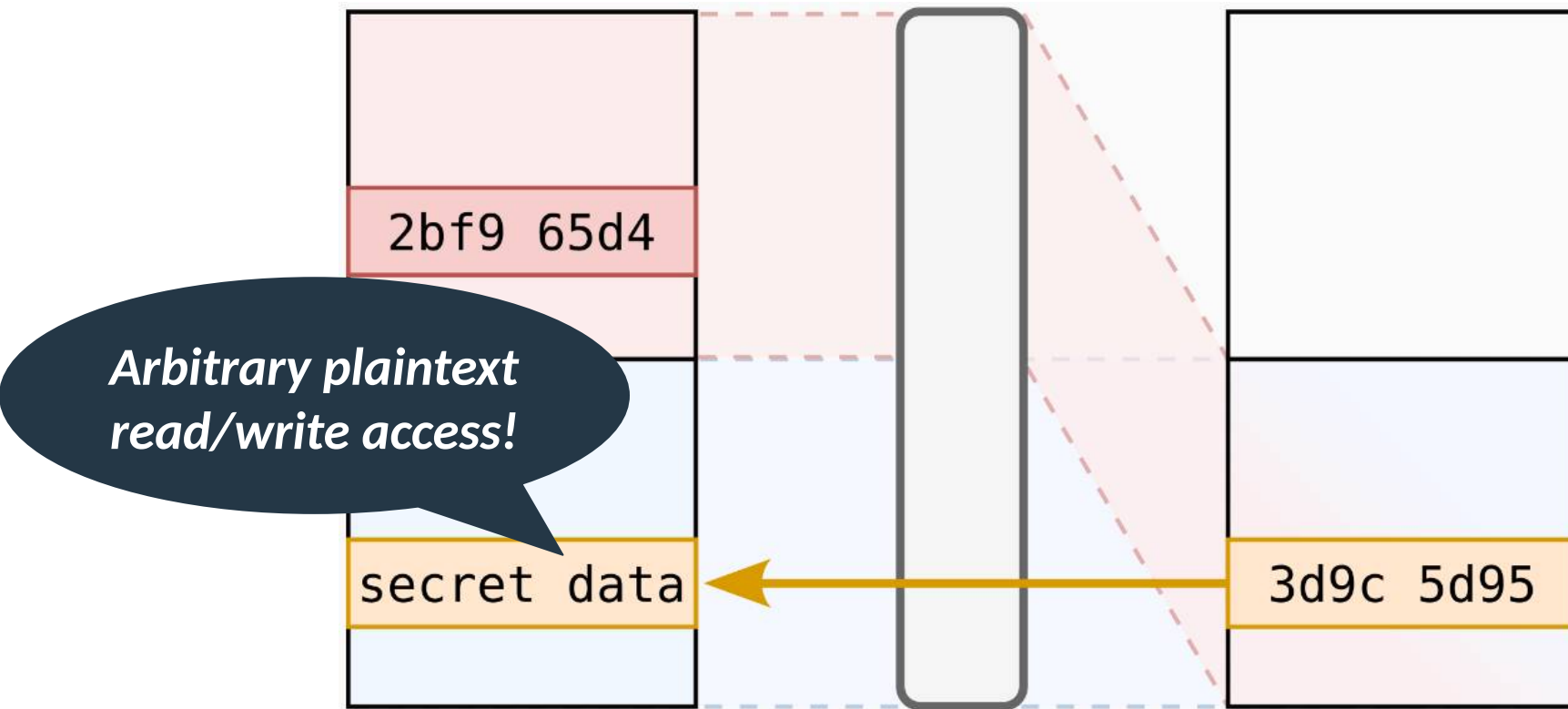
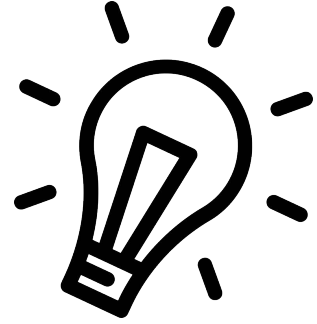



Demo

**Arbitrary plaintext access on Intel
Scalable SGX**

Intel and AMD trusted enclaves, a foundation for network security, fall to physical attacks

The chipmakers say physical attacks aren't in the threat model. Many users didn't get the memo.

DAN GOODIN - 30 SEPT 2025 22:25 | 67

The Hacker News

🏠 Home

✉ Newsletter

Cheap Hardware Module Bypasses AMD, Intel Memory Encryption

Researchers built an inexpensive device that circumvents chipmakers' confidential computing protections and reveals weaknesses in scalable memory encryption.

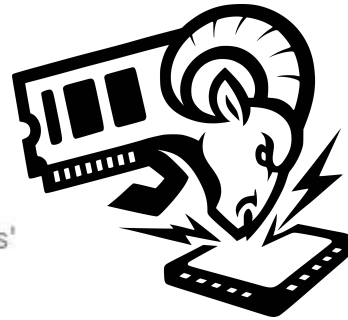

New \$50 Battering RAM Attack Breaks Intel and AMD Cloud Security Protections

 <https://batteringram.eu/>

CLOUD SECURITY

Battering RAM Attack Breaks Intel and AMD Security Tech With \$50 Device

Intel and AMD say the research is not in scope of their threat model because the attack requires physical access to a device.



By Eduard Kovacs | October 1, 2025 (4:50 AM ET)



SEV-SNP Physical Memory Aliasing

AMD ID: AMD-SB-3024

Potential Impact: N/A

Summary

Researchers have reported a method for privileged attackers with physical access to a motherboard to potentially compromise confidentiality and integrity of AMD Secure Encrypted Virtualization – Secure Nesting Paging (SEV-SNP) guests.

AMD does not plan to release any mitigations in response to this report because the reported exploit is outside the scope of the published threat model for SEV-SNP, as detailed in Table 1 of the [AMD SEV-SNP technical paper](#).^{pdf}

<https://www.amd.com/en/resources/product-security/bulletin/amd-sb-3024.html>

More Information on Encrypted Memory Frameworks for Intel Confidential Computing

ID	Updated	Version	Public
865767	10/27/2025	1.0	Public

In the *Battering RAM* paper, researchers from KU Leuven and University of Birmingham developed a custom interposer to actively alias memory and gain arbitrary read/write access into Intel SGX-protected memory.

Both research teams assume a physical adversary has direct access to the hardware with a memory bus interposer. Both methods can then be used to attack Intel SGX-protected assets, including Intel SGX attestation keys. In a separate disclosure to Intel, Fortanix provided a potential attack that requires a replay-capable physical interposer. **Such attacks are outside the scope of the boundary of protection** offered by Advanced Encryption Standard-XEX-based Tweaked Codebook Mode with Ciphertext Stealing (AES-XTS) based memory encryption, as originally stated in the 2021 Intel publication [Supporting Intel® SGX on Multi-socket Platforms](#). As it provides limited confidentiality protection, and no integrity or anti-replay protection against attackers with physical capabilities, Intel does not plan to issue a CVE.

<https://www.intel.com/content/www/us/en/developer/articles/news/more-information-encrypted-memory-frameworks.html>

Technical Position Paper on Confidential Computing

In this position paper, ANSSI outlines its views on Confidential Computing. It recalls the attack models that Confidential Computing purports addressing, its main security mechanisms and their current limitations. It also provides guidelines to Cloud Service Providers and other companies developing security products.

As mentioned before, Confidential Computing is often presented by commercial providers as a solution to run remote workloads with the same level of confidentiality and integrity as a local setup, *i.e.* resistant to a physical attack. However, **physical attacks are explicitly out-of-scope of the security target defined by hardware vendors**. This means in particular that if a user is concerned about a cloud-provider conducting targeted attacks, instead of relying on a Confidential Computing approach they need to switch to a cloud-provider they trust, *i.e.* with strong counterparts or control capabilities, or use their own hardware with physical security protection measures. Likewise, the security of Confidential Computing assumes an uncompromised Manufacturer TCB: manufacturer and supply-chain attackers, including state-level ones, are thus explicitly out-of-scope.

<https://cyber.gouv.fr/en/publications/technical-position-paper-confidential-computing>

Conclusions and Take-Away



1. Confidential computing is here to stay...



2. Challenge your attacker models

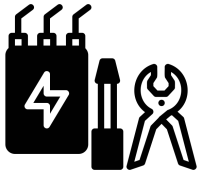

3. Hardware attacks are practical

